

・使用説明. 和訳. 送料. 送料. 送料.

・仕様比較表 (D4)

・大主存変置所 (D4) 改訂点 GM.

送料. 送料.

Des I ¥3000.

Astoria. 15/100.11.11
¥1800

NOITAMHOMI IARSUHO

4-(2)+2

70:00

①

Tool.

TRADE house = tax

Astoria = BIG AUSTRALIA

= Enastoria

SERVICE MANUAL FOR COMPUTERIZED SEWING MACHINE

COMPUTERIZED

ULT2001

SUPER GALAXIE 3000

COMPUTERIZED

GENERAL INFORMATION

This service manual has been compiled for explaining repair procedures of the MODEL ULT2001 SUPER GALAXIE 3000.

This was produced based on up-to-date product specifications at the time of issue, but there may have been changes of specifications for the purpose of improvements.

Contact manufacturer or local sales company for information concerning such changes.

Brother Industries, Ltd.
Nagoya, Japan

CONTENTS

I . PRINCIPAL MECHANISMS.....	1
II . DISASSEMBLING AND REASSEMBLING THE SEWING MACHINE	8
III . HOW TO ADJUST MECHANICAL ELEMENTS.....	23
IV . HOW TO ADJUST ELECTRONIC ELEMENTS	55

CAUTION

1. Always use rubber gloves when handling printed circuit boards and never touch the metal portion of a printed circuit board with bare hands.
2. Keep your body earthed in order to avoid generating static electricity.
3. Pack printed circuit boards in aluminum foil and avoid subjecting them to any form of impact during storage or transportation.
4. Do not touch or damage the metal portion of a printed circuit board with a screwdriver or any other tool while making repairs or the like.

I. PRINCIPAL MECHANISMS

1. MECHANICAL CHART.....	2
2. POWER TRANSMISSION CHART.....	3
3. ELECTRONIC PARTS ARRANGEMENT CHART.....	4
4. CONTROL SYSTEM BLOCK DIAGRAM.....	5
5. MAIN MOTOR CONTROL.....	5
6. PATTERN GENERATOR.....	6
7. AUTOMATIC THREAD TENSION.....	6
8. OTHER ELECTRONIC COMPONENT FUNCTIONS.....	7

1. MECHANICAL CHART

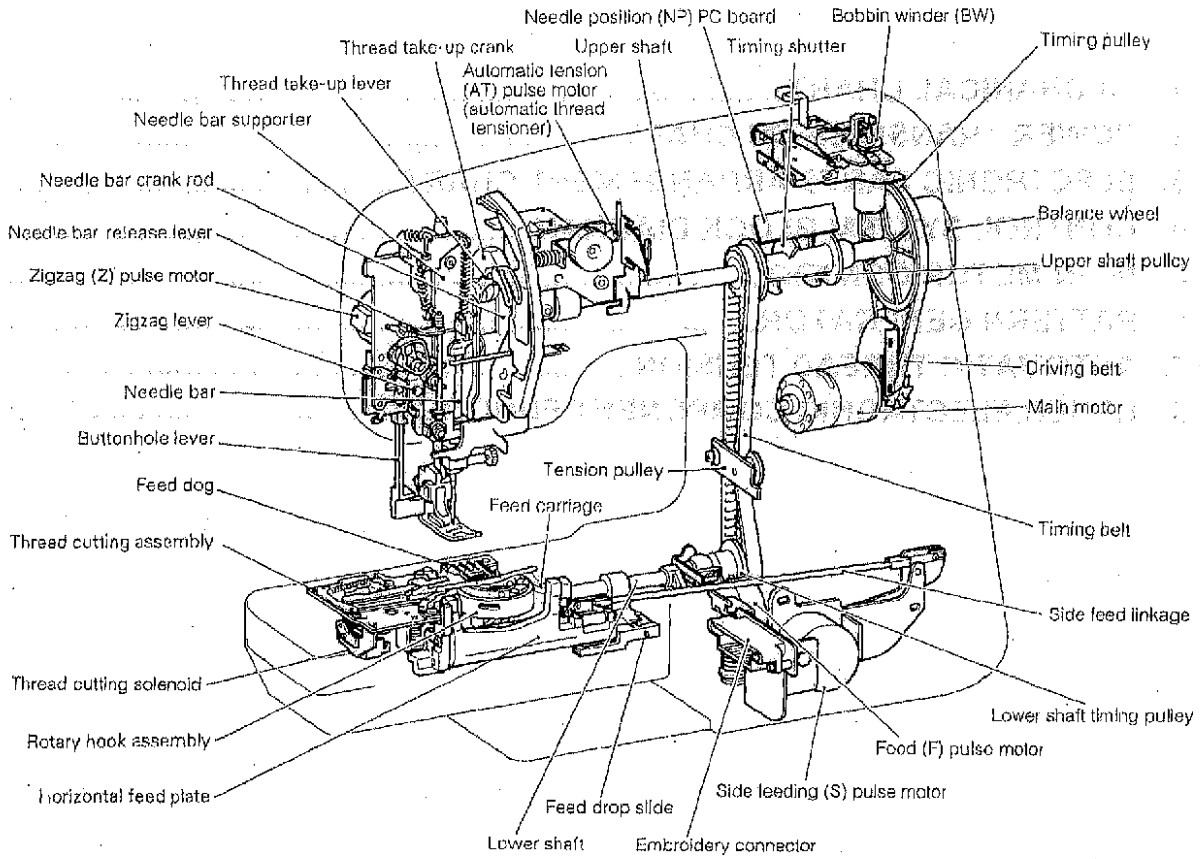

EMBROIDERY UNIT MECHANISM

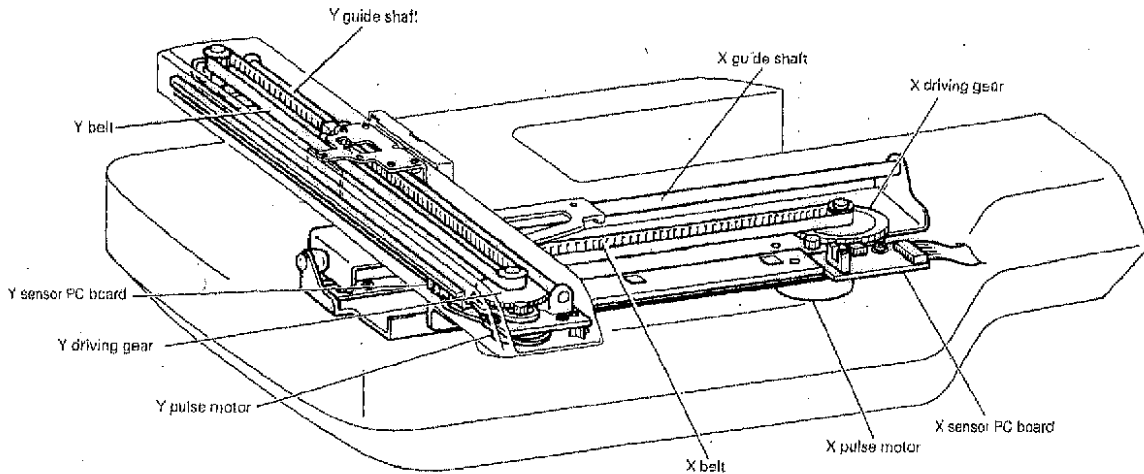

2. POWER TRANSMISSION CHART

(A) Generating mechanism of needle bar, thread take-up lever and zigzag movements

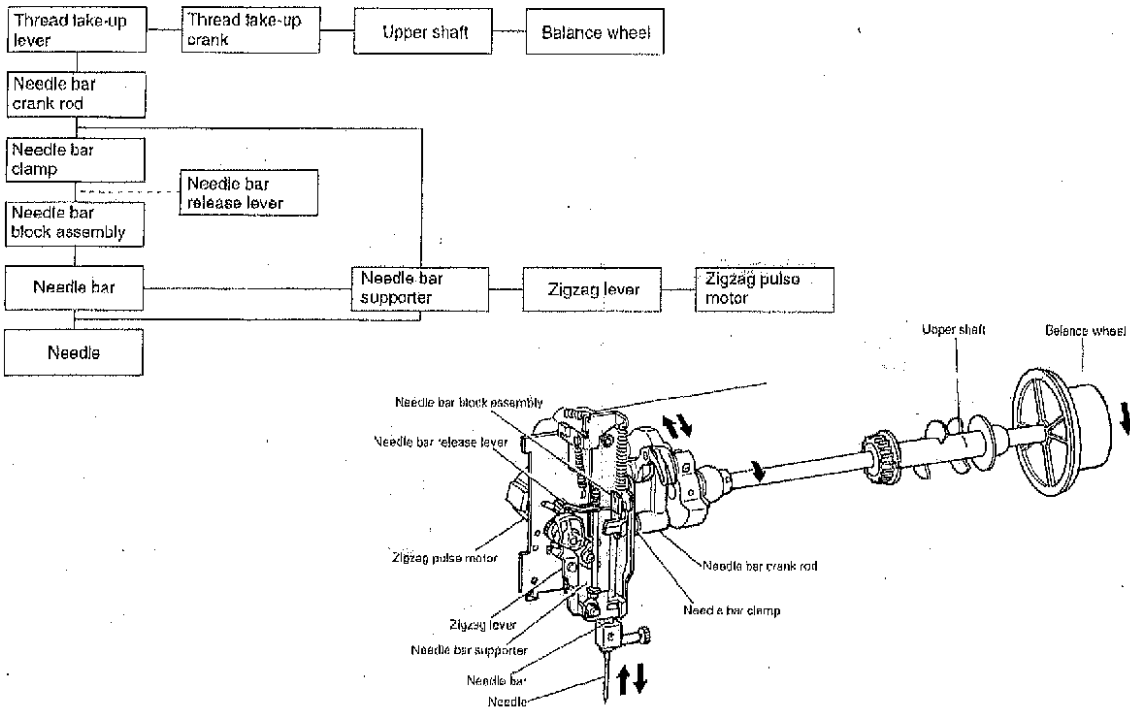

(B) Mechanism of feed dog and rotary hook movement

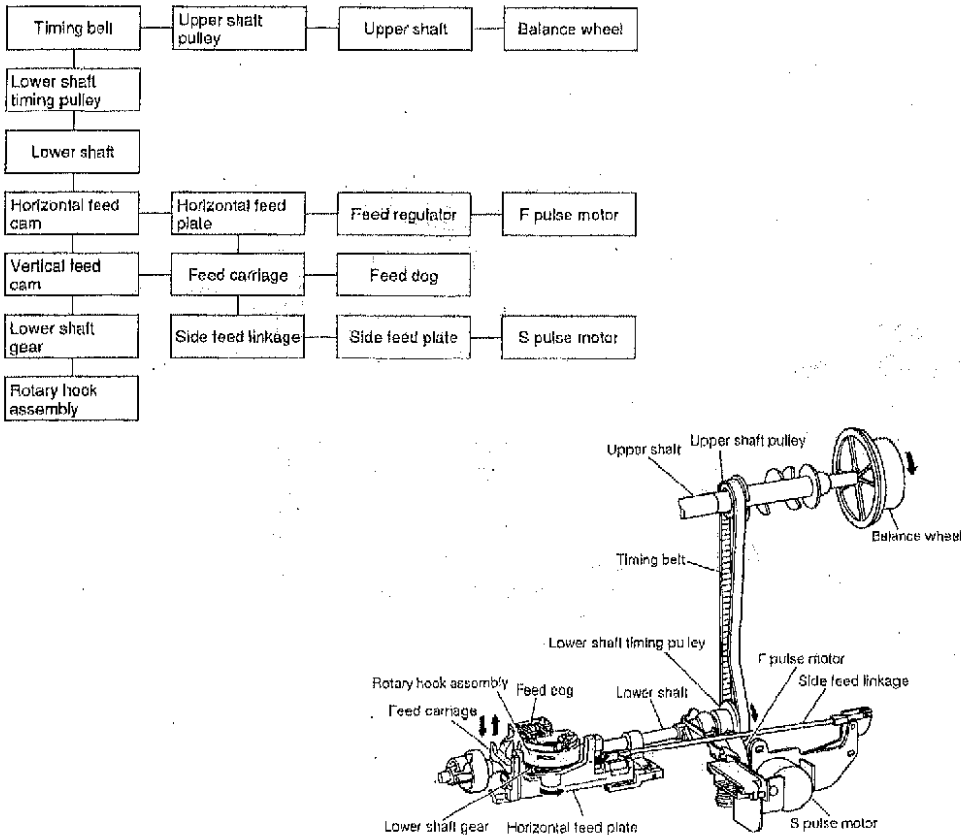

3. ELECTRONIC PARTS ARRANGEMENT CHART

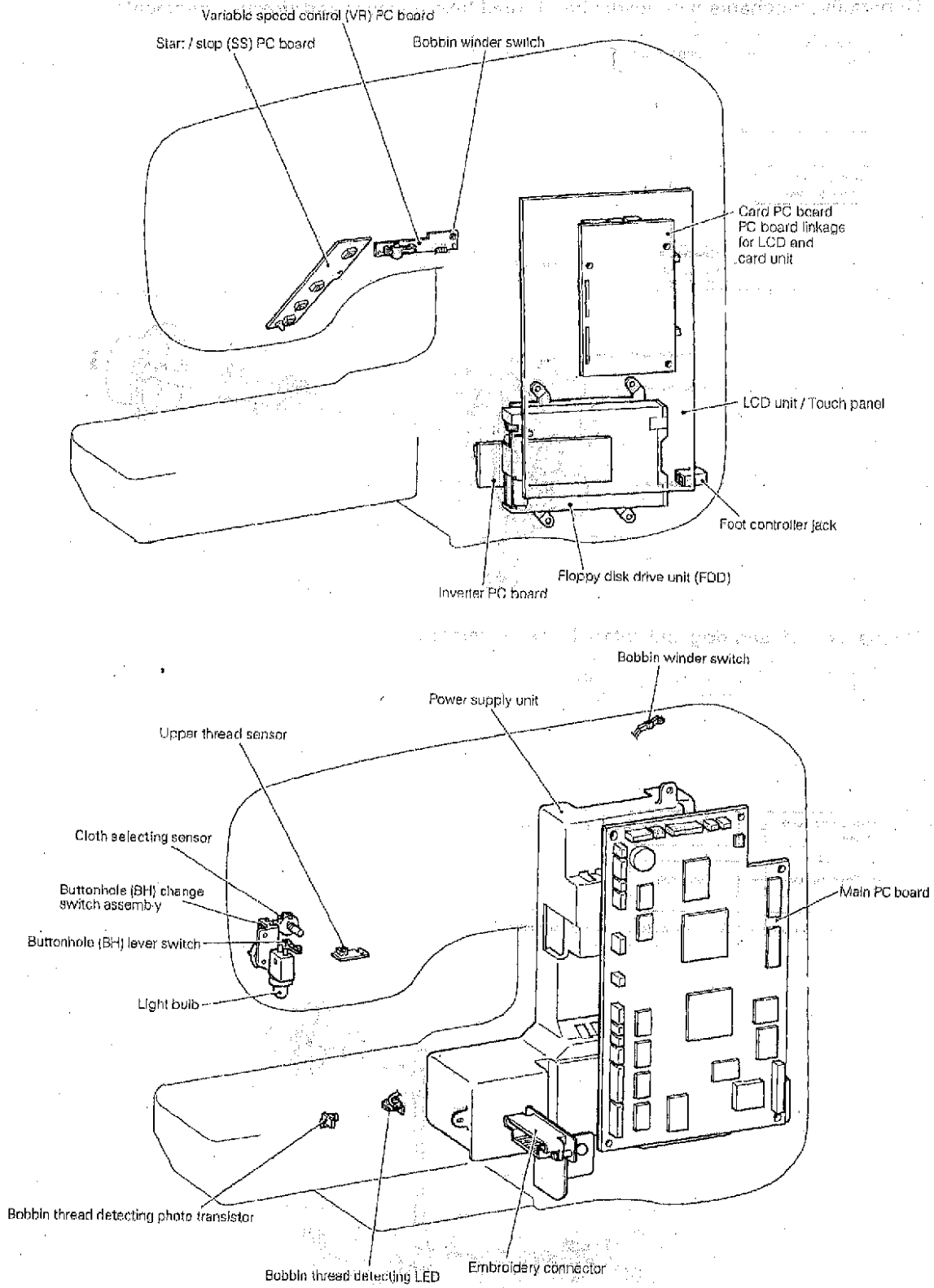

4. CONTROL SYSTEM BLOCK DIAGRAM

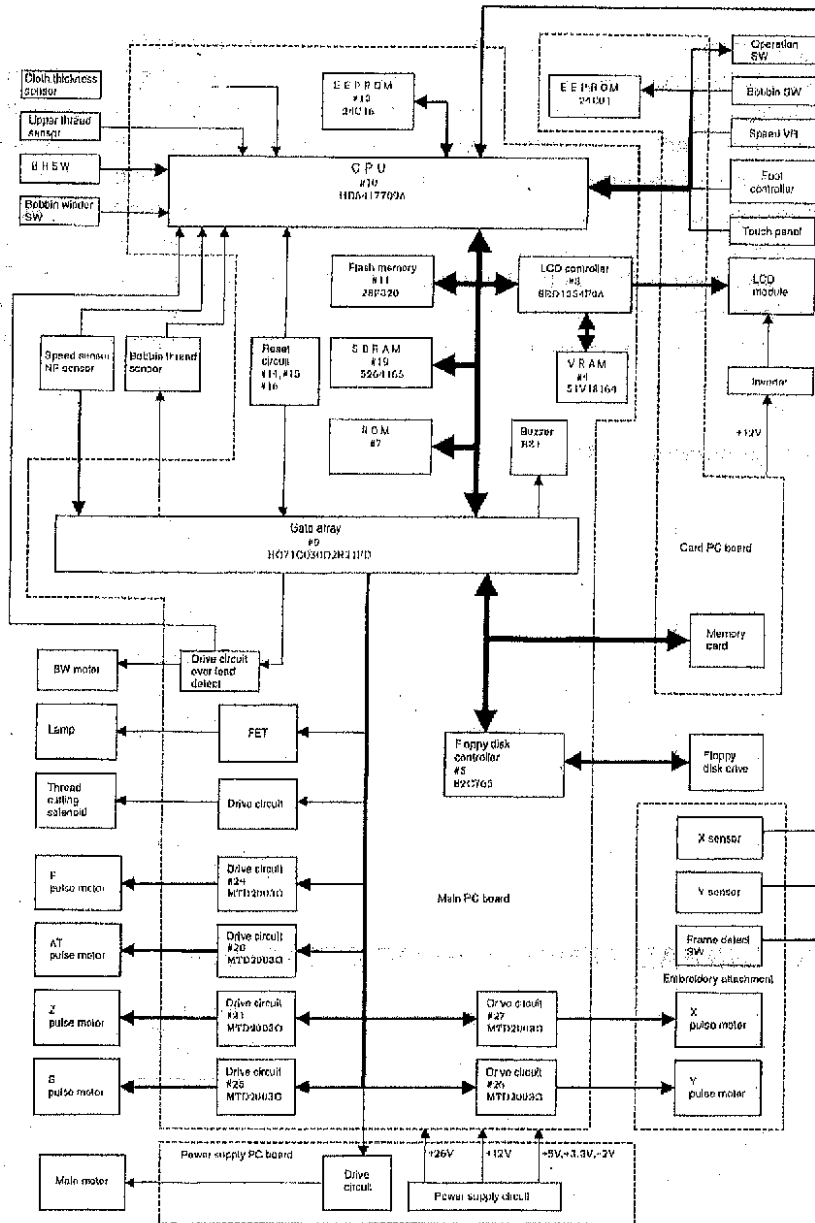

5. MAIN MOTOR CONTROL

The main motor for the sewing machine is required to smoothly change from low speed to high speed without any fluctuations due to load or temperature changes. To fully comply with this requirement this machine adopts Pulse width modulation (PWM) control using Field Effect Transistor (FET).

6. PATTERN GENERATOR

For conventional sewing machines, the pattern was generated by rocking the needle bar and the feed regulator by means of a pattern cam onto which the pattern data had been mechanically engraved. In contrast to this, this model stores the data electronically in memory and uses a feed pulse motor, horizontal pulse motor and a zigzag pulse motor to directly rock the needle bar and the feed regulator to generate the pattern. As a result of this, it is possible to increase the number of patterns and the number of stitches simply by adding extra memory capacity, so that about 3,800 patterns comprising a total of approximately 20,000 stitches can be stored. In addition, the pulse motors must move the position of the needle while the needle is raised and stop it in the correct position (and similarly, they must move the position of the feed regulator while the needle is lowered). Thus, highly-precise positioning and a fast response speed are required. Because of this, the feed pulse motor, horizontal pulse motor and a zigzag pulse motor were adopted, and a simple open-loop structure circuit structure was employed.

Block diagram of pattern generator control

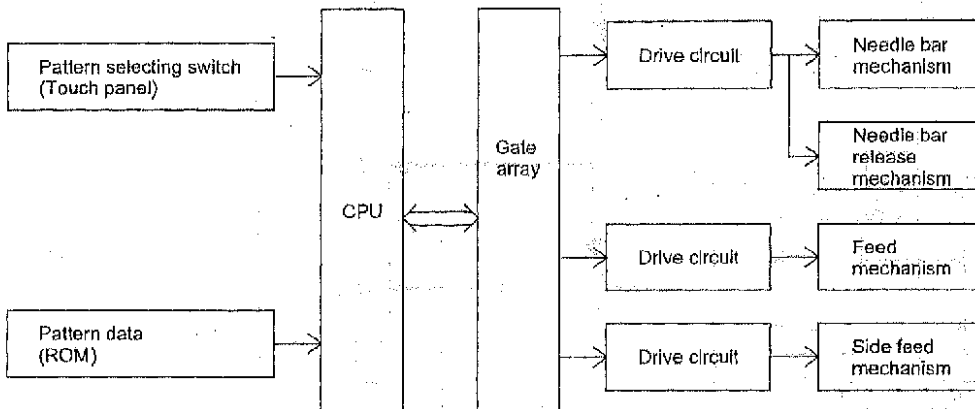

7. AUTOMATIC THREAD TENSION BLOCK DIAGRAM

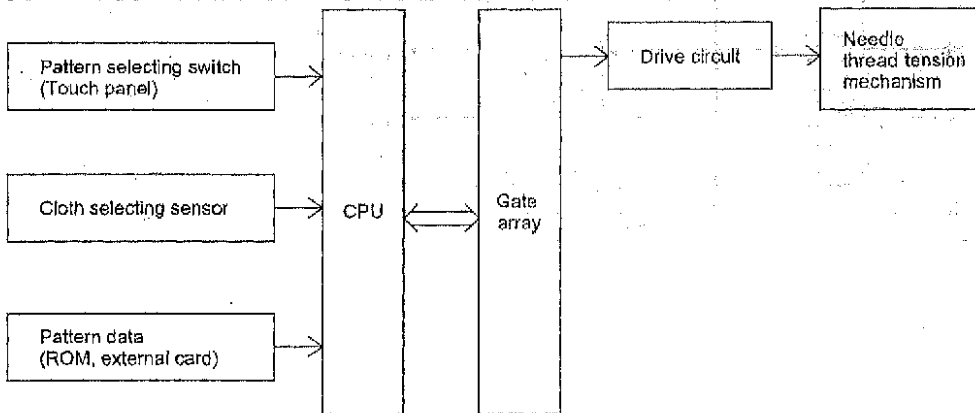

8. OTHER ELECTRONIC COMPONENT FUNCTIONS

- Start/stop switch used to start and stop (SS) the machine. If you want to start sewing at low speed, keep this switch depressed and start sewing.
- Backstitch switch used for backstitching and lockstitching. Backstitching is performed at low speed in the reverse direction while the switch is pressed. For lockstitching, three stitches are made at the current needle position and then sewing stops.
- Needle position (UP/DOWN) switch.... used to change the needle position either up or down.
- Automatic thread cutter switch used to cut the thread automatically. When you press this switch, the machine will automatically cut the thread, regardless of the needle position, and stop with the needle at its upper position.
- Touch panel..... used to select pattern and input test mode number required for sewing by simply touching the display on the panel. This simplifies the operation for selecting the desired pattern and number.
- Buttonhole stitch switch..... used to detect the edges of the buttonhole stitch by means of the buttonhole stitch presser foot and lever.
- Buttonhole stitch lever switch used to detect whether the buttonhole stitch lever is raised or lowered.
- Speed sensor used to detect the rotation speed of the main motor. detects the operating speed of the main motor by means of a photointerruptor and shutter installed on the upper shaft.
- Bobbin winder start stop switch..... used to start stop the bobbin winding.
- Bobbin winder switch..... used to detect whether the bobbin winder has been set when winding the lower thread.
- Foot controller jack when using the foot controller, connect it to this terminal.
- Transformer..... used for driving the pulse motors and solenoids, to illuminate the lamps and to supply power to the electronic circuitry.
- Light bulb is 12V 5W.

II. DISASSEMBLING AND REASSEMBLING THE SEWING MACHINE

1. DISASSEMBLING AND REASSEMBLING THE OUTER PARTS AND MAIN PARTS.....	9
2. LEAD WIRE ARRANGEMENT.....	22

1. DISASSEMBLING AND REASSEMBLING THE OUTER PARTS AND MAIN PARTS

1. Remove the screw securing the face plate, and the face plate by sliding it to the left.
2. Remove the screw securing the free arm cover, and the free arm cover by sliding it to the left.
3. Remove the notch on the right side of the upper cover, and while holding it to the right remove the upper cover.
4. Remove the one screw on the front thread guard cover, then remove the front thread guard cover.
5. Remove the screw securing the front cover (at back right side of handle), and loosen the two screws (below jaw section on face plate side, below free arm). Open the front cover toward the front, remove the three connectors and then the front cover.
(When removing the connectors, always release the lock on the main board connector first.)
(When the front cover has been removed, always adjust the touch panel after assembling the front cover.)
6. Remove the screws at the 4 locations, then remove the FDD unit.
7. Remove the two screws securing the needle plate, and the needle plate.
8. Remove the three screws securing the rear cover, and the rear cover from the rear side.
9. Remove the two securing screws, then remove the thread winder cover.

Disassembly Points

5. To remove the front cover, slide part (D) up, unhook the two catches (H) from the base plate and the jaw section of the front cover (E) from the bottom of the thread guide, then pull the front cover away at the front.
* Before disconnecting the flat cable connector (F), be sure to release its lock.
(Disconnecting the flat cable with the connector locked will damage the terminals and cause the keys to stop operating correctly.)
8. Before removing the rear cover, lower the presser foot lifter.

70-176-7X
 フラットケーブルの
 キーボード
 リヤカバーの時
 押さえておく

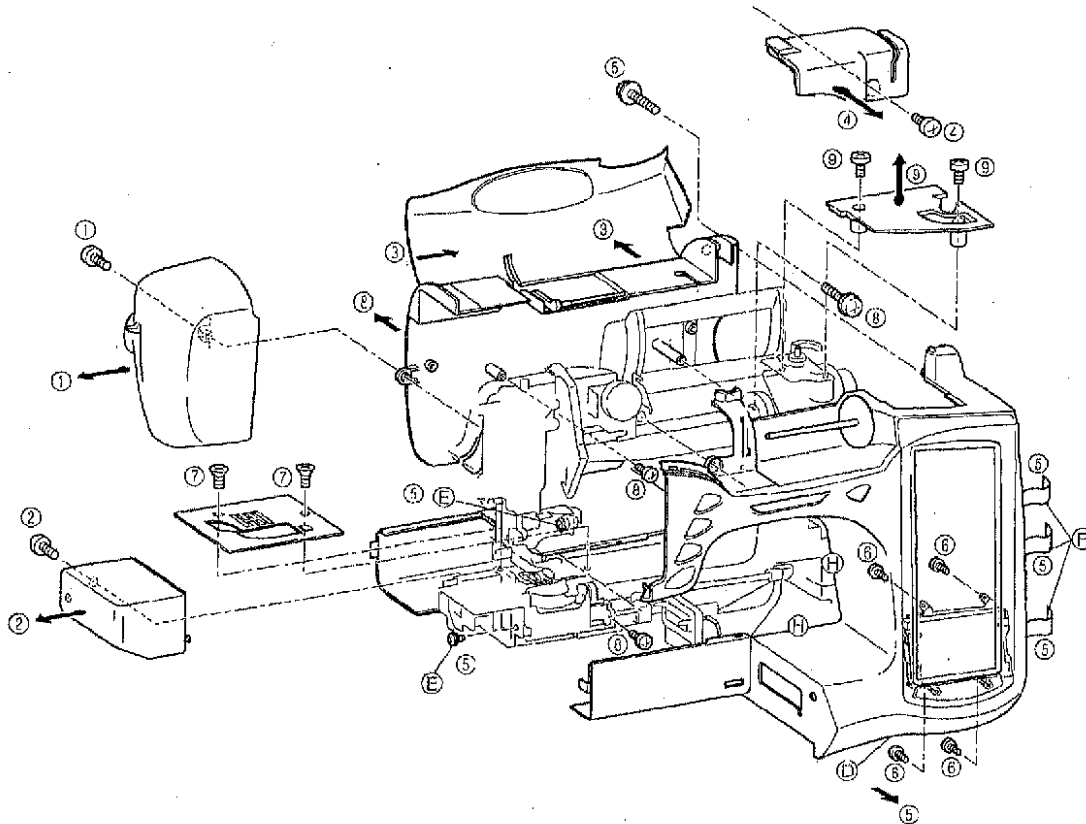

10. Remove the presser holder and needle.
11. Remove the 17 connectors, the four screws, and the main PC board.
12. Remove the screw and thread winding assembly.
13. Remove the three screws and NP base assembly.
14. Remove the two washers. Remove the 2 screws and the wire support plates, Remove the wire assembly.
15. Remove the inlet assembly connector. Then the 3 screws and base plate assembly.
16. Remove the two screws on the left. Remove the two screws and the side feed assembly.
17. Remove the two screws and the FPM holder.
18. Remove the spring, and remove the two screws. Remove the thread tension assembly.
19. Remove the screw and the needle bar supporter stud holder assembly.
20. Remove the two springs (B) and the needle bar block assembly.
21. Remove the two screws and the two cord holders.
22. Remove the three screws and the ZPM assembly.

Disassembly Points

11. To disconnect the connectors, grab the base of the connector and pull it straight out.
 * In order to reduce the risk of static electric damage to the main PC board after it is removed from the sewing machine, do not touch the board's front surface and only carry it by its edges in the same way that you hold a compact disk.
19. To remove the needle bar supporter stud holder, move it upward while removing it from the pin.

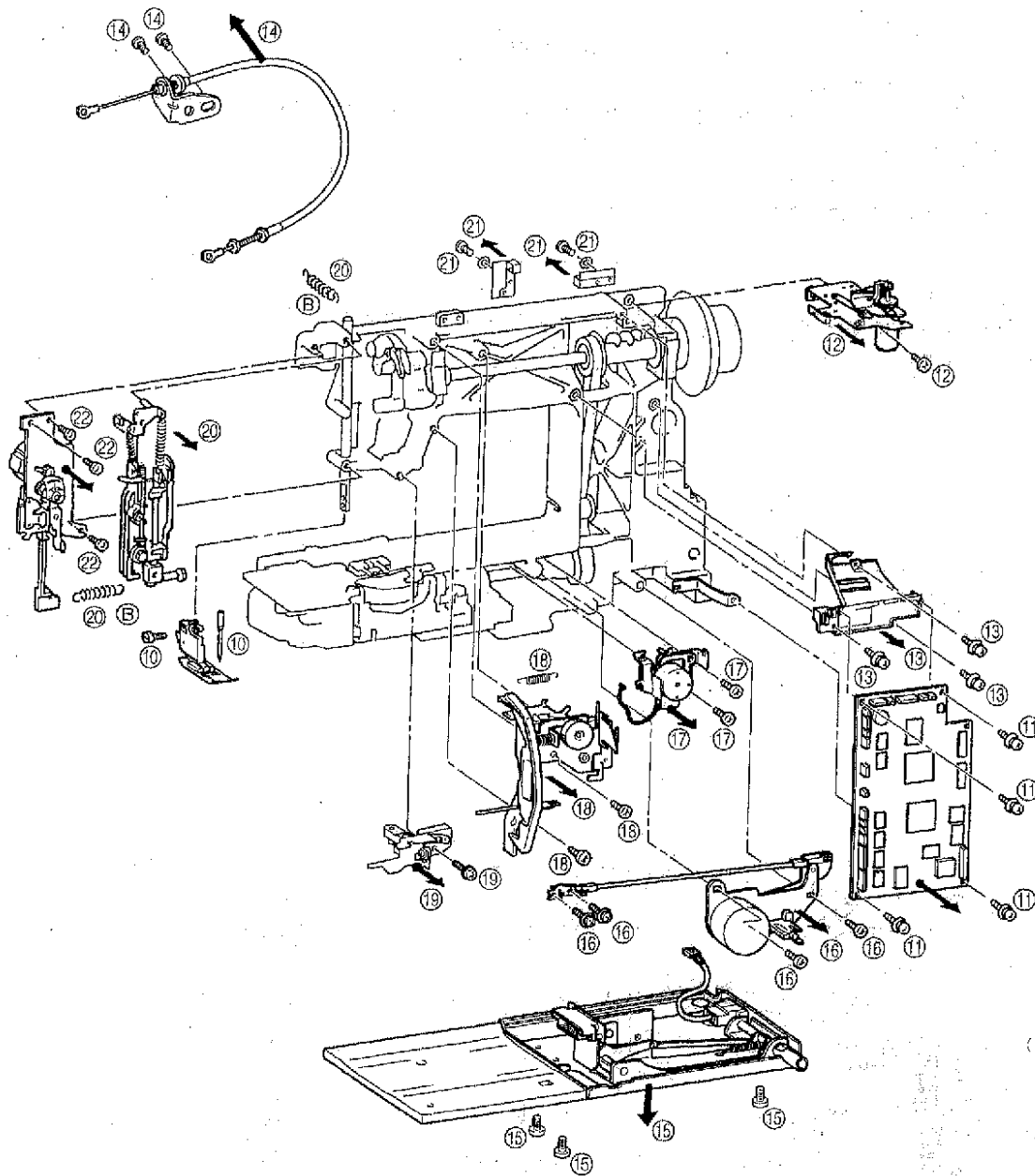

23. Remove the connector, then remove the two screws and the thread cutter unit.
24. Remove the screw and the inner rotary hook rotation prevention bracket.
25. Remove the presser bar clamp screw.
26. Remove the presser bar by lifting it from above, and the presser bar clamp and presser spring.
27. Remove the two screws, and remove the presser frame assembly.
28. Remove the presser lifting shaft by pulling it out from the back, the presser lifter and lifter.
29. Remove the screw and the thread take-up shaft.

Disassembly Point

23. Before removing the thread cutting assembly, move the thread cutter cam so that its notch faces the front of the sewing machine (A).

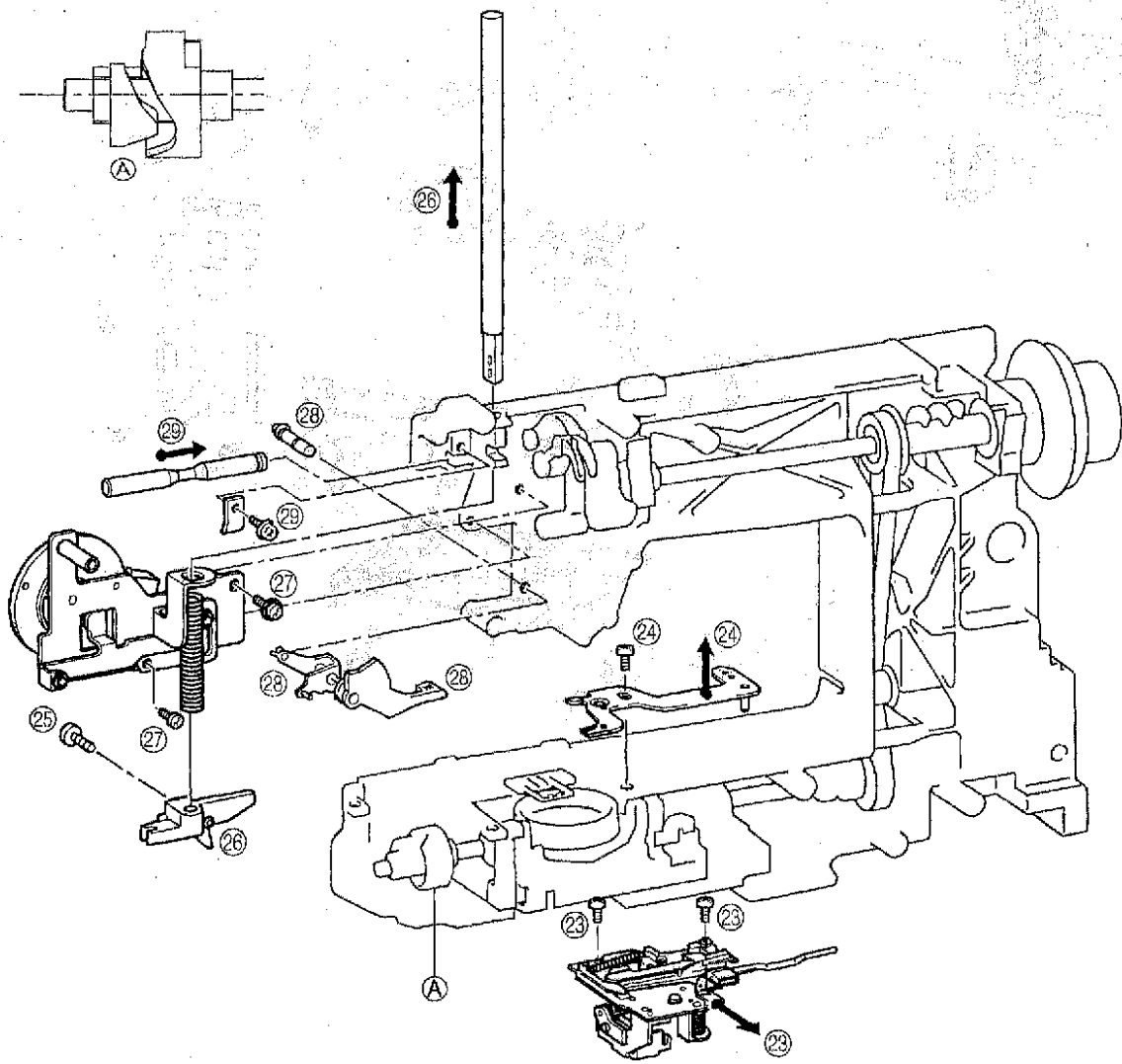

30. Remove the 4 screws from the horizontal feed shaft supporter and the feed adjustment unit shaft supporter. Remove the horizontal feed assembly.
31. Pull out the motor connector. Remove the 3 screws and the power supply unit.
32. Remove the motor belt and the 2 screws and the main motor.
(When removing the motor from the motor holder, remove the motor fan then remove the 2 screws.)
33. Remove the four screws and the handle.
34. Remove the screw and the tension pulley holder.
35. Remove the two screws securing the upper shaft metal, the upper shaft assembly and the timing belt.
36. Remove screw and the outer rotary hook assembly.
37. Remove the both presser plate screws. Remove the lower shaft assembly and the timing belt.

Disassembly Points

30. Before removing the horizontal feed assembly, remove the feed bar tension spring (C).

上下送り機構
外す。

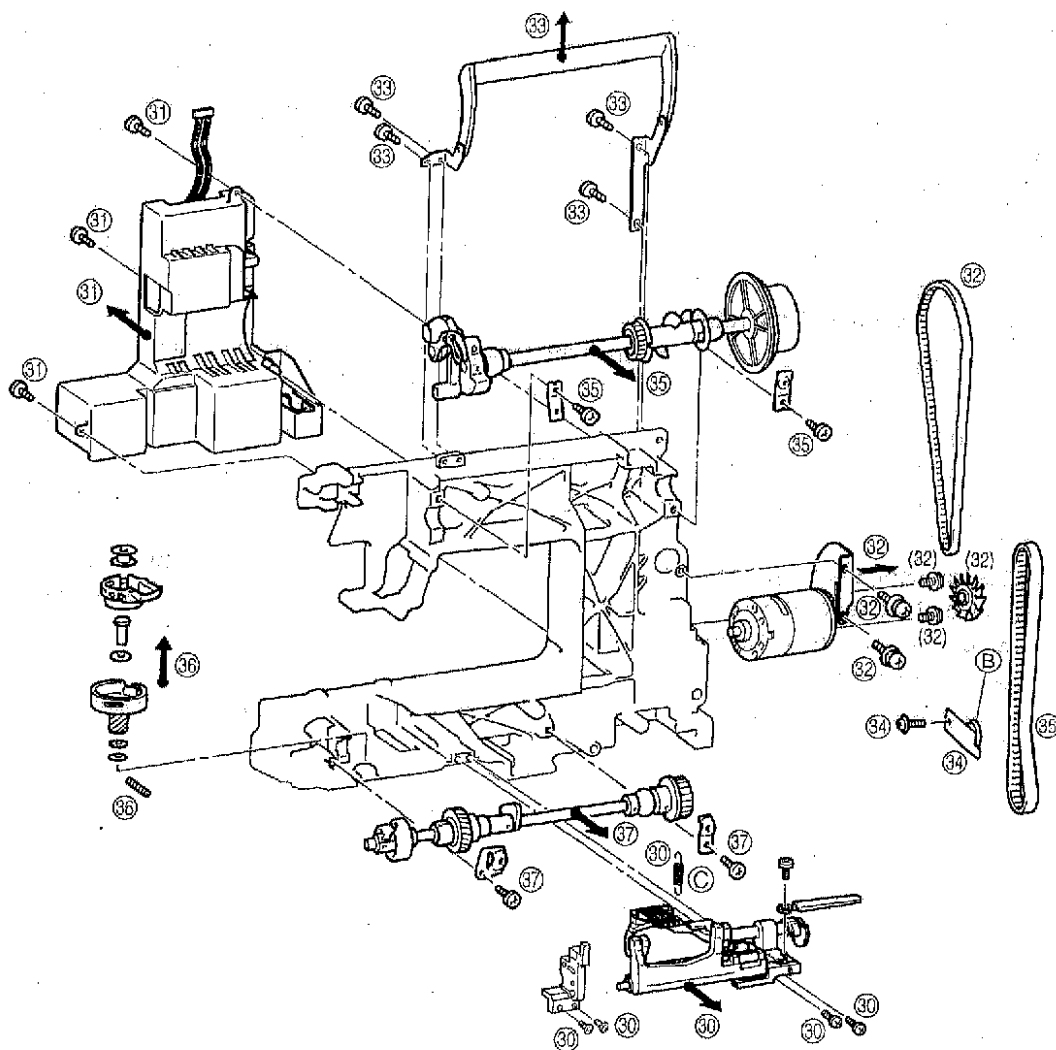

38. Use the presser plate and the screw to attach the lower shaft assembly.
39. Position the outer rotary hook assembly and the three washers to the lower shaft assembly (see following page) and attach with the screw.
40. Run the upper shaft through the timing belt and attach with the two presser plates and the screws.
41. Attach the tension pulley holder with the screw.
42. Attach the handle with four screws.
43. Attach the main motor using the two screws and catch the motor belt.
(When attaching the motor to the motor holder, tighten the two screws and then attach the motor fan.)
44. Attach the power supply unit assembly using the three screws connect the motor connector.
45. Use the 2 screws to attach the horizontal feed shaft supporter. Use the two screws to attach the horizontal feed assembly. Attach the feed stand spring.

Assembly Points

38. When attaching the lower shaft assembly, do so with notch of the lower shaft eccentric metal (A) facing forwards and slot (B) in uppermost position.
38. After lower shaft is attached, make sure that the lower shaft moves freely. If it does not move freely, lightly tap the lower shaft metal presser (J) with a punch, or similar tool, and check again.
39. When attaching the outer rotary hook assembly, attach so that lower shaft base hole (C) of the thread cutter cam and the outer rotary hook assembly baseline (D) are positioned towards the front.
39. * Attach so that thick end of the rotary hook shaft washer is in on top.
39. * Adjust position of notch of eccentric metal to adjust play of the outer rotary hook assembly and the lower shaft (rotation direction slack of the outer rotary hook assembly). Positioning the notch at the bottom will reduce play. Under normal conditions, the ideal position is towards the front. However, when play is excessive, adjust to prevent the rotary hook noise.
41. After tension pulley is attached, adjust tension of the timing belt. (see (H) for reference.)
* After attaching the timing belt, adjust rotation torque of the timing belt.
41. When attaching the timing belt, do so when notch (G) of the horizontal feed cam of the timing belt and the lower shaft baselines (C) and (F) are facing positioned on the front side.
43. Apply a pressure of 1N (100 g) at the center of the motor belt, then adjust its tension until it only moves 1.5 to 3.5 mm (B).
* If the belt is too tight, the torque becomes too much, causing the motor to rotate slower and generate an irregular noise. If the tension is too loose, the belt may jump and the upper shaft may not rotate smoothly while sewing on denim and other thicker fabrics or overlapping fabrics.
45. Check back and forth movement of feed stand.
* If free movement is hindered, feed pitch is inhibited or a forward and backward motion is inhibited.

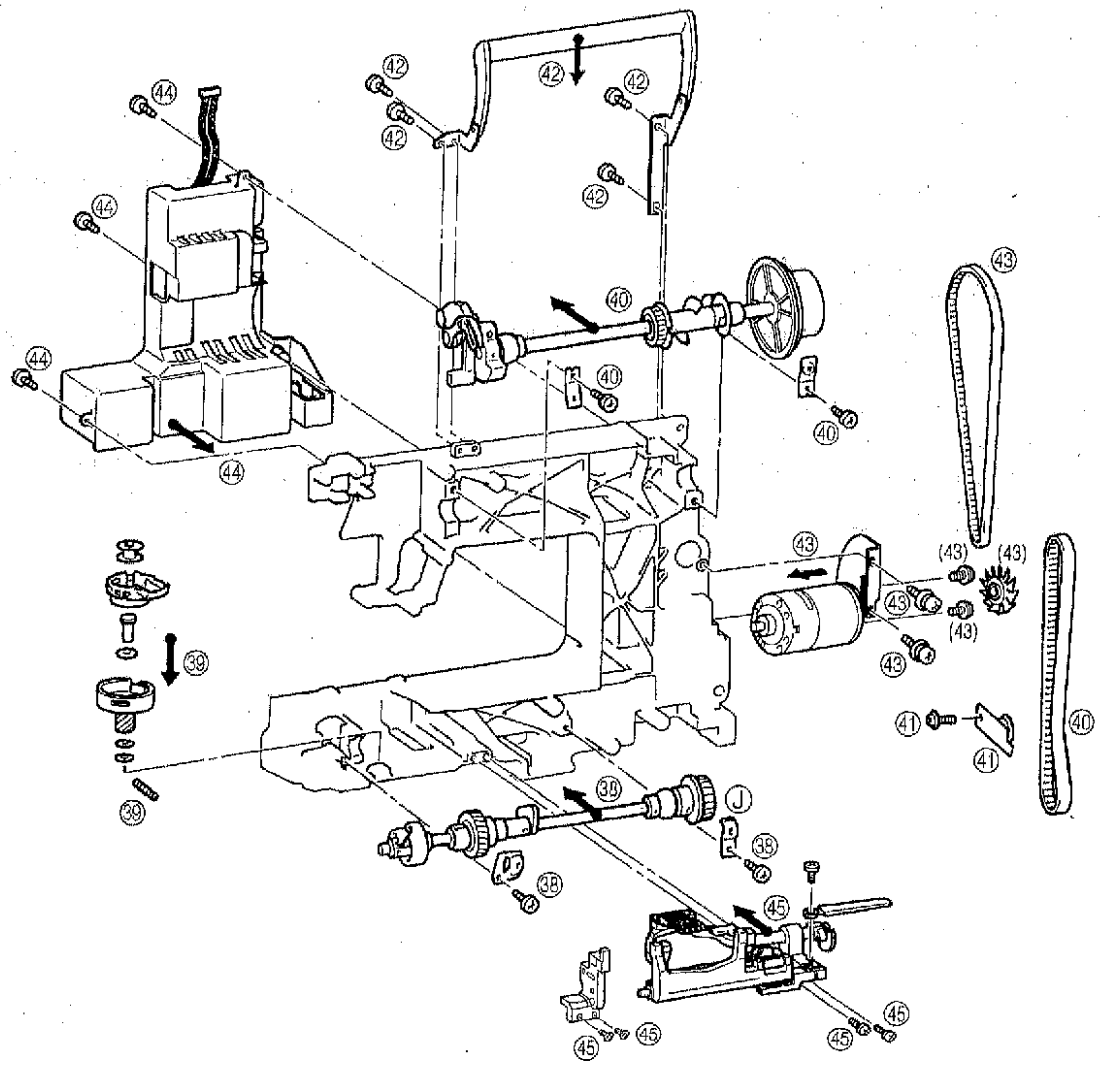
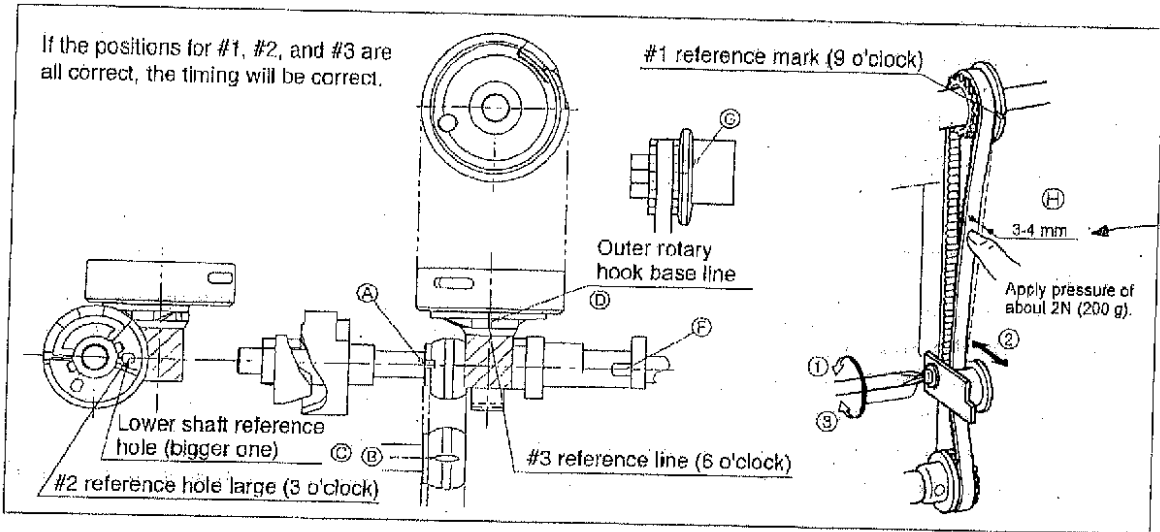

46. Attach the thread take-up shaft using the screw and presser plate.
47. Attach the lifter and the presser foot lifter with the presser foot shaft.
48. Attach the presser frame assembly using the two screws.
49. Insert and attach the presser bar with spring into the presser bar clamp.
50. Attach the presser bar clamp screw.
51. Attach the inner rotary hook rotation prevention plate using the screw.
52. Attach the thread cutter unit using the two screws connect the thread cutter solenoid connector.

Assembly Points

46. The thread take-up lever shaft should be installed so that there is no gap between the right side of the thread take-up and the stop ring. If there is a large gap, the right and left clearance may generate an irregular noise (thread take-up lever noise).
51. Install the inner rotary hook bracket assembly. (Firmly tighten the screw to make no space between (D) and the arm so that the inner rotary hook bracket assembly does not rotate.)
- * After the inner rotary hook bracket assembly is installed, adjust the position where rotation is prevented. (Refer to (A).)
 - * If there is a small rotation prevention amount, the inner rotary hook may slip and start rotating causing damage to the inner rotary hook or breaking the needle.
52. Before installing the thread cutting assembly, move the thread cutter cam so that its notch faces the front (B) of the sewing machine.
52. Thread cutting assembly installation procedure
- (1) Insert the projection (C) on the cutter unit into the arm guide hole.
(Insert the projection while checking that the inner rotary hook is correctly positioned.)
 - (2) Move the thread cutting assembly toward the right without bending the lower thread guide arm assembly to install it.
- * After installing the thread cutting assembly, perform the following procedure to check that the movable blade operates correctly.
- (1) With the lever pin pressed in by hand, turn the balance wheel by hand to begin operating the movable blade.
 - (2) When the movable blade is at its rightmost position, release the lever pin and turn the balance wheel, then check that the movable blade lightly returns to its previous position.
- * If the movable blade does not operate correctly, loosen the screw (52), move the thread cutting assembly forward and backward, then move the unit toward the right and tighten the screw.

針支のステ.
、HICの向度
Dの位置
（前）Dの位置
加位置
6の2の外に
見
6の1の位置
位置の
見
針の位置
手
-Eの作業
(針の7)

↓

・ステの確認
・右方向

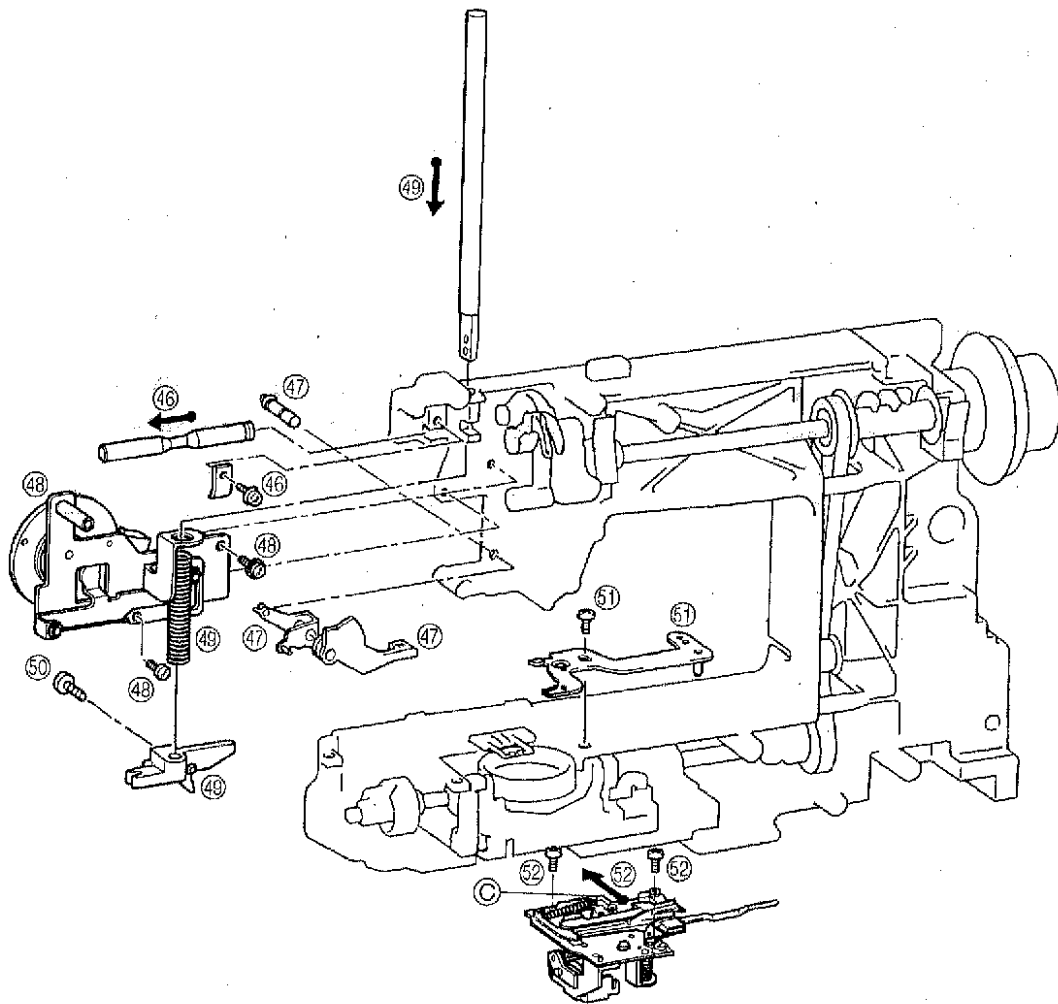
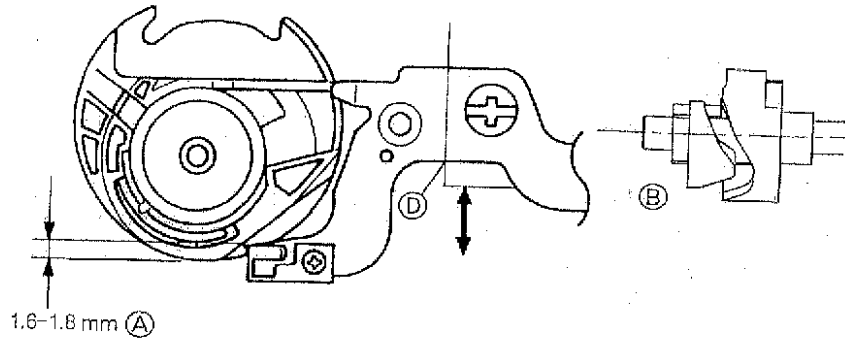

53. Attach the ZPM holder assembly using the three screws.
54. Wrap the lead wire cord, then tighten the 2 screws on the 2 cord holders.
55. Attach the needle bar supporter assembly using the two springs. (Insert into the needle bar clamp and needle bar crank rod)
56. Attach the needle bar supporter stud holder using the screw. (Insert the needle bar supporter arm into the pin on the needle bar supporter.)
57. Insert the pin, and attach the thread tension assembly using the two screws and the spring.
58. Attach the FPM holder assembly using the two screws.
59. Attach the side feed shaft using the 2 screws on the left and attach the side feed assembly with 2 screws.
60. Attach inlet assembly connector. Attach the base plate assembly using the three screws.
61. Attach wire assembly using the four screws. Use the two washers to hook up to lift wiring.
62. Attach the NP base assembly using the three screws. Pass the wires from the back side through hook section (E) of the NP base assembly.
63. Attach the thread winder assembly using the screws.
64. Attach the main board assembly using the four screws. Connect the 17 connectors.
65. Attach the presser holder and needle.

Assembly Points

53. When installing the ZPM holder assembly, the cloth selecting sensor lever should be put on the presser bar clamp.
* If the cloth selecting sensor lever slips down, the cloth selecting sensor cannot operate and the thread tension cannot be adjusted.
55. Before installing the needle bar supporter assembly, insert it into the needle bar crank rod, insert the needle bar supporter stud holder, then install a spring. Hook the longer end of the other spring (F) to the main unit.
56. Install the needle bar supporter stud holder from the needle bar supporter pin side, then attaching it using a 14 mm screw.
58. When installing the FPM holder assembly, align the guide points of the F gear and the FPM gear.
63. When installing the bobbin winder assembly, align the tab (C) in the bobbin winder assembly holder with the positioning hole in the sewing machine.
64. Insert the connectors correctly and pass the lead wires under the guides (E).

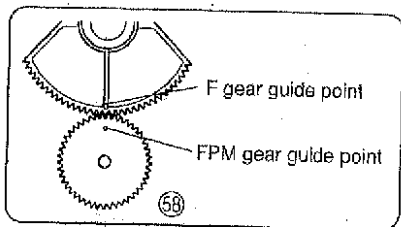
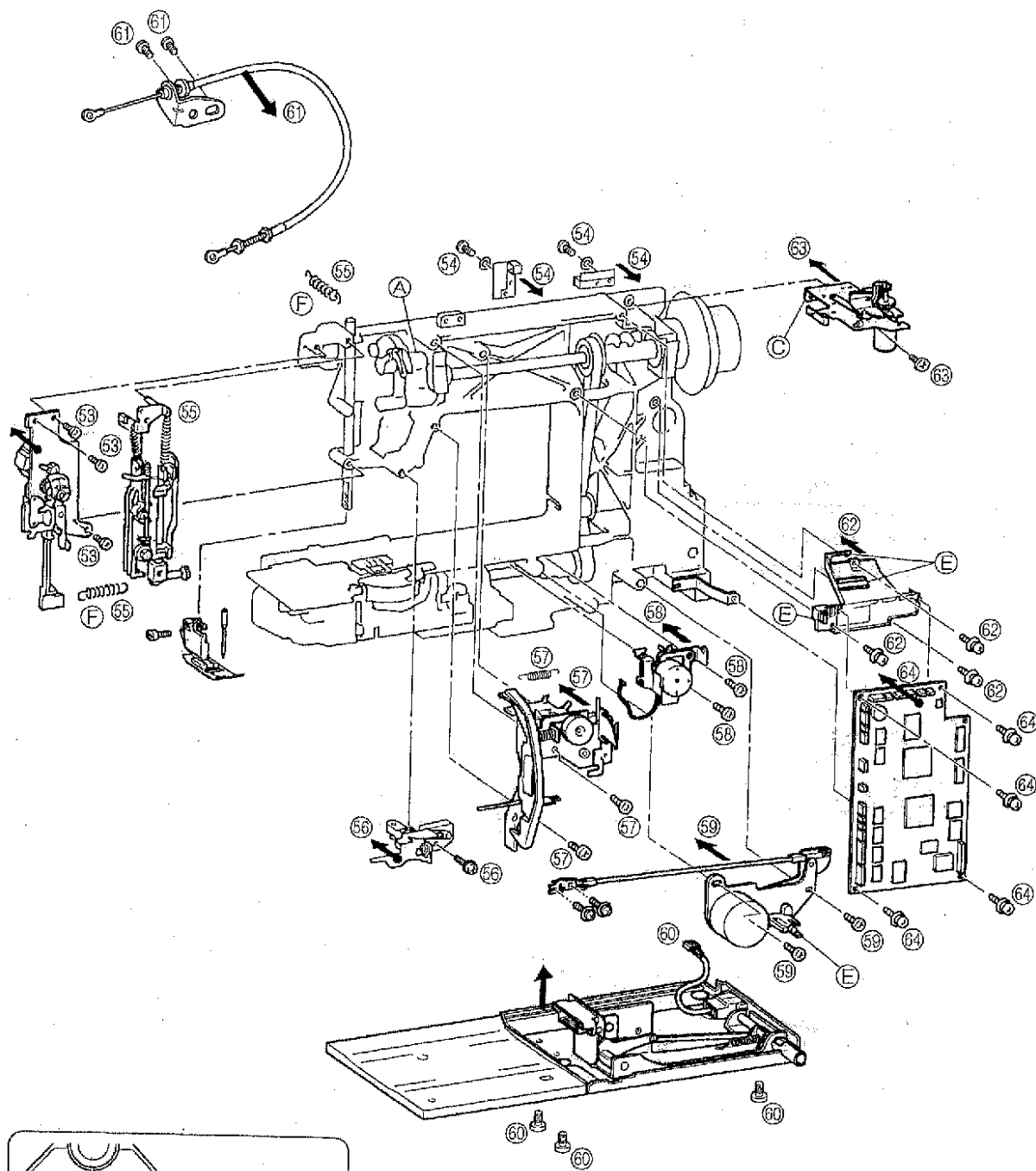

66. Put the thread winder cover on the thread winder assembly.
67. Attach the rear cover using the three screws.
68. Attach the needle plate assembly using the two screws.
69. Connect the three connectors, and attach the front cover using the three screws.
(When inserting connectors, confirm that the lock on the main board connector is open.)
(When the front cover has been removed, always adjust the touch panel after assembling the front cover.)
(Use the 4 screws to attach the FDD.)
70. Attach the front thread guard cover using the one screw.
71. Attach the thread winder cover using the two screws.
72. Insert the hose on the left of the upper cover into the hole of the rear cover, then insert the notch plate on the right side of the rear cover to attach.
73. Attach the free arm cover using the screw.
74. Attach the face plate using the screw.

Assembly Points

67. When installing the rear cover, lower the presser foot lifter, slightly down the back of the unit, then install the rear cover.
70. When installing the ~~thread winder~~ ^{front thread} cover, insert Pin (B) of the thread tension assembly into the indentation of the front thread cover (A).
71. When installing the thread winder cover, align with the front cover and rear cover, then install.

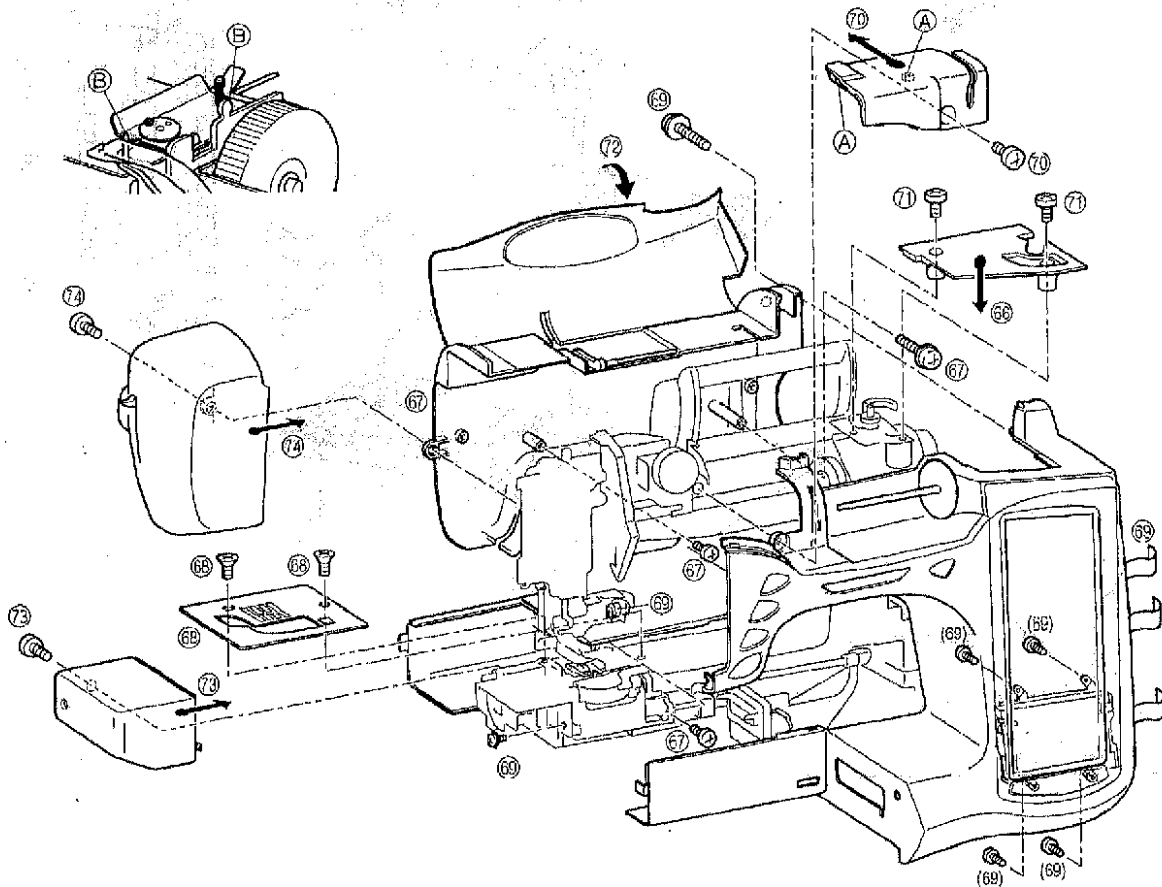

DISASSEMBLING AND REASSEMBLING THE EMBROIDERY UNIT

1. Remove the screw and X carriage cover.
2. Remove the screw, and remove the YPM cover.
3. Remove the four screws and pull the main cover to the right.
4. Remove the four screws and the base cover.
5. Attach in the opposite order from when disassembling the unit.

Assembly Point

3. Check to make sure that there is space between sensors on X and Y shutters.
Set X sensor lead wire and X pulse motor lead wire in section (A). Attach main frame, taking care not to pinch cord.
Attach so that the YPM lead wire, frame detection SW lead wire, and Y sensor lead wire pass under the couching clip (B).
Move X carriage side to side to make certain that Y sensor lead wire and YPM lead wire do not come into contact with main frame and main cover during movement of X carriage.

コードは20番まで

コードクリップの
糸針付、コードは20番

コード整理の
石巻

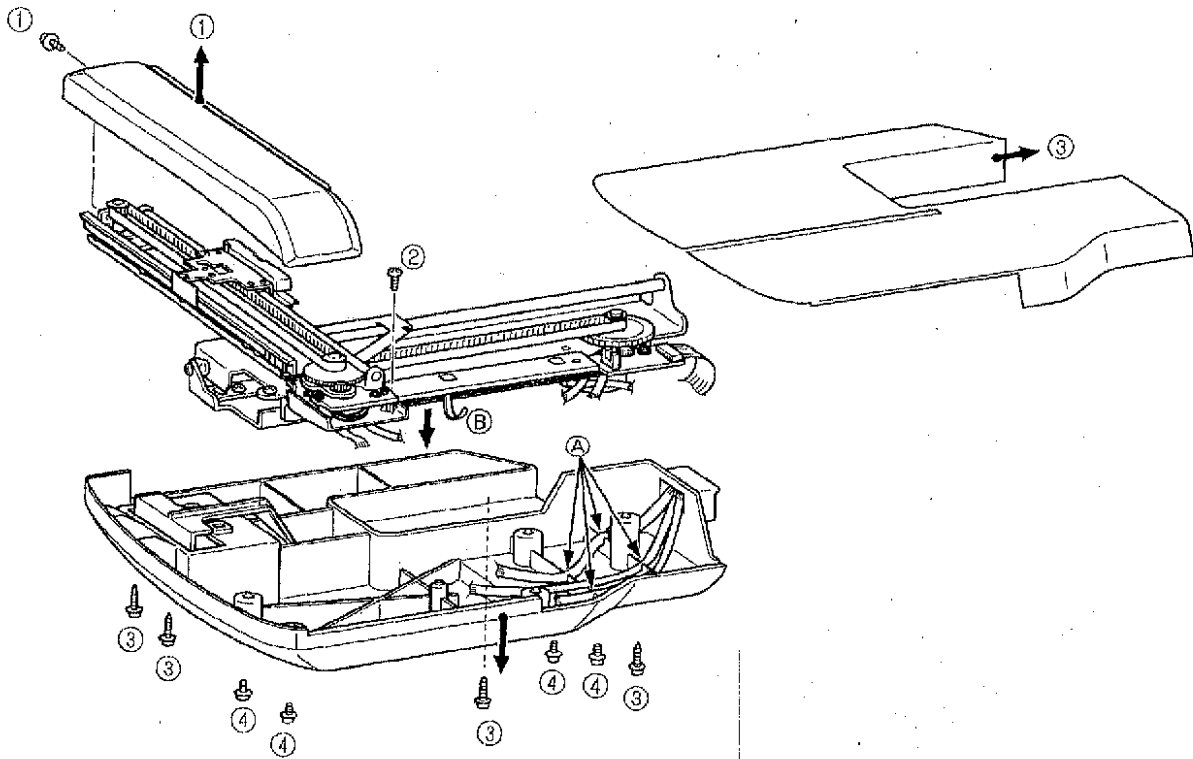

2. LEAD WIRE ARRANGEMENT

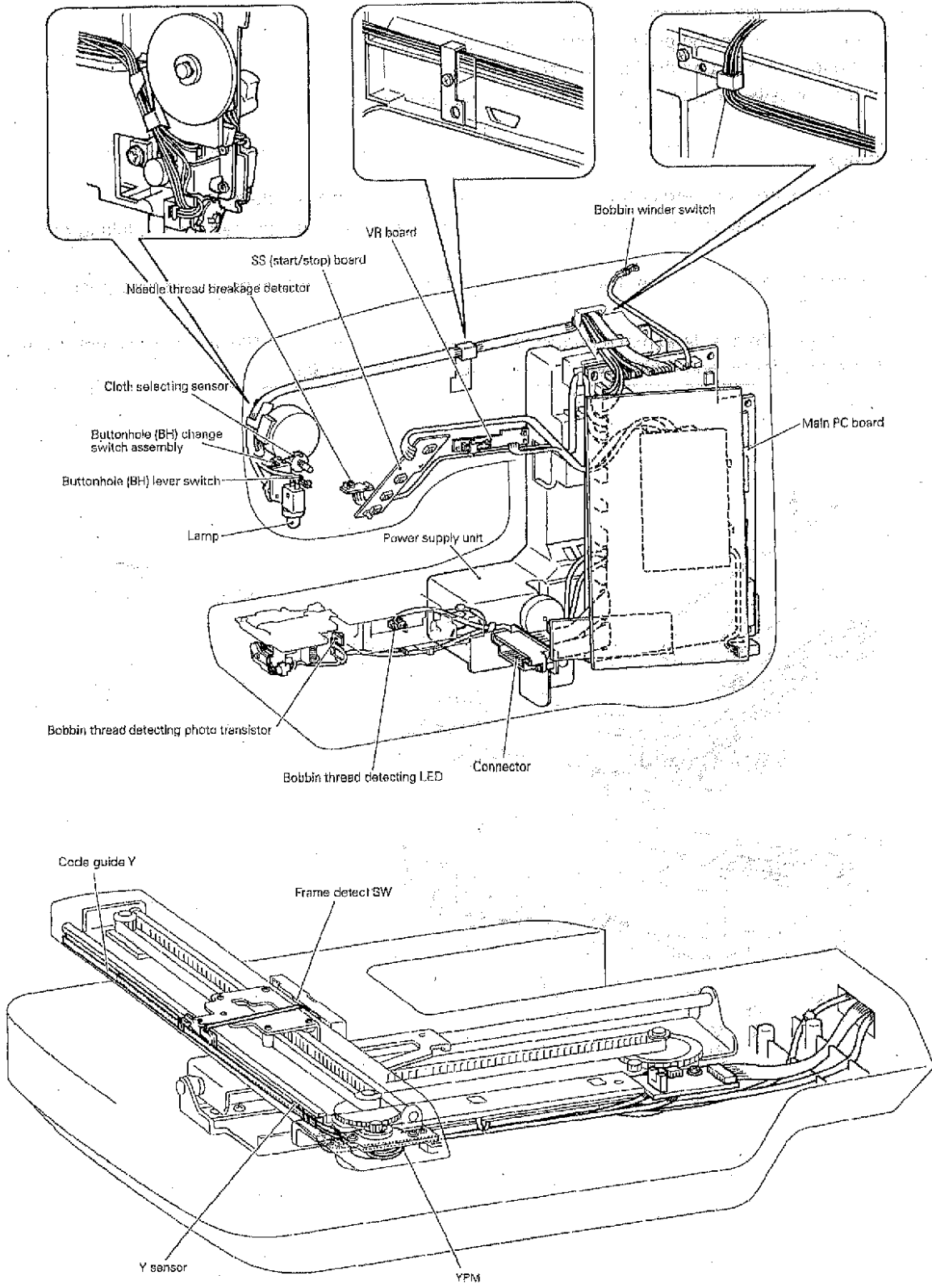

III. HOW TO ADJUST MECHANICAL ELEMENTS

1. POSITION OF TOUCH PANEL (Be sure to adjust the touch panel after reconnecting the touch panel connector.).....	24
2. SETTING THE TEST MODE	25
3. TENSION OF MOTOR BELT AND TIMING BELT	29
4. NEEDLE DOWN POSITION ADJUSTMENT	30
5. TIMING OF NEEDLE AND ROTARY HOOK (CLEARANCE BETWEEN THE NEEDLE AND THE ROTARY HOOK POINT) .	32
6. NEEDLE BAR HEIGHT	33
7. LOWER SHAFT.....	34
8. FRONT/BACK, LEFT/RIGHT POSITION OF FEED DOG.....	35
9. PRESSER BAR HEIGHT	37
10. CHECKING DETECTION OF FABRIC THICKNESS (If a new main PC board is installed, this adjustment must be performed.) ..	38
11. HEIGHT OF FEED DOG	39
12. TENSION ADJUSTMENT	40
13. POSITION OF BUTTONHOLE SWITCH LEVER	41
14. BOBBIN WINDER.....	42
15. BOBBIN THREAD DETECTOR.....	43
16. INNER ROTARY HOOK BRACKET POSITION.....	44
17. LARGE ONE-POINT PATTERN SHAPE (SOFT ADJUSTMENT).....	45
18. FEED ADJUSTMENT (VERTICAL FEED).....	46
19. INNER ROTARY HOOK TENSION.....	47
20. KNEE LIFTER	47
21. NEEDLE THREADER	48
22. NEEDLE THREADER (CHECKING THE HOOK POSITION IN HORIZONTAL DIRECTION)	49
23. NEEDLE THREADER (EXCHANGE).....	50
24. NEEDLE THREADER (CHECKING THE HOOK IN STANDARD POSITION)	51
25. NEEDLE THREADER (CHECKING THE HOOK POSITION IN VERTICAL DIRECTION).....	51
26. TIMING BELT TENSION FOR THE X DIRECTION.....	52
27. TIMING BELT TENSION FOR THE Y DIRECTION.....	53
28. FD UPGRADE PROCEDURE	54

1. POSITION OF TOUCH PANEL

(Be sure to adjust the touch panel after reconnecting the touch panel connector.)

STANDARD

The deviation between the liquid crystal display and touch panel should be within 1 mm when the touch panel is pressed.

ADJUSTMENT

1. While pressing the start/stop, reverse stitch and needle position buttons, turn on the power to display the screen for the touch panel adjustment mode.
2. Touch the touch panel at the positions marked by crosses (+) in order from 1 to 5.
(When touching the touch panel, use the included touch pen. Never use a hard or sharp-pointed object.)
If the buzzer sounds once when cross number 5 is touched, the adjustment has been made correctly and the square will be displayed in "Black".
If the buzzer sounds 4 times when cross number 5 is touched, an error has occurred and the square will be displayed in "Red". In this case, touch the crosses on the touch panel again in order from 1 to 5.
Never press the thread cutter button during this time. (Doing so may cause a malfunction.)
3. Turn the power off, then on again and check that the screen display and the touch panel positions are aligned.

Adjustment Point

If the buzzer sounds more than twice while making adjustment (2), perform the procedure again from the beginning since the position has not been correctly set.

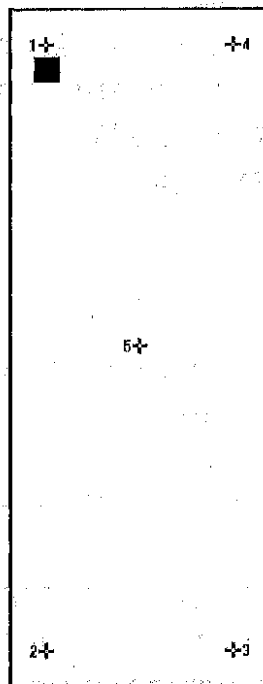

Touch panel adjustment screen

2. SETTING THE TEST MODE

BASIC TEST MODES

To set the test mode, turn on the power switch while holding down the start/stop button and backtack button simultaneously. Numerals will appear on the touch panel. The respective test mode will be entered when the numeral is pressed.

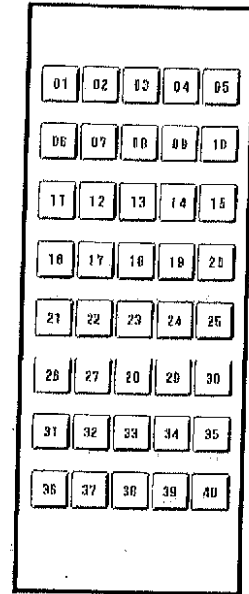
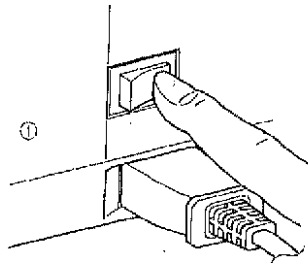
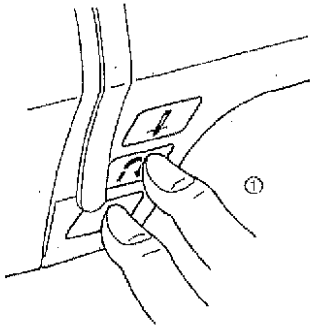

NO	Test Name	Contents	Notes
NO01	Serial number of machine on display	Displays the serial number of the machine	<div style="border: 1px solid black; padding: 2px; display: inline-block; margin-bottom: 10px;">01</div> <p style="text-align: center;">SERIAL NUMBERS</p> <p style="text-align: center;">A011111111</p>
NO02	Fabric thickness setting	Refer to 38	
NO03	Pattern adjustment	Refer to 45	
NO04	3-point needle drop	Refer to 30	
NO05	Needle clearance	Refer to 32	
NO06	Feed dog position	Refer to 35	

0-25

NO07 Feed dog height	Feed dog height Refer to 39	07 Presser foot height + 0.0
NO08 Whip stitch	Whip stitch pattern	08 Whip stitch pattern
NO09 Sample fabric straight line	Sample fabric straight line	09 Sample fabric straight line
NO010 Bobbin thread detector condition display mode	Refer to 43	
NO011 Upper thread breakage sensor display mode	Upper thread breakage sensor display mode Sensor penetration time (when there is no thread): 00 No sensor penetration: ++	11 Upper thread 0.0
NO012 Upper thread breakage function cancel mode	Upper thread breakage function – function cancel Upper thread breakage detection function cancellation (next time power is turned on, can only be used one time)	12 Upper thread
NO013 Reverse and forward feed	Correct reverse feed	

NO014 Rotation count mode	Rotation count mode Check maximum rotation count When the maximum rotation count (850 RPM) is measured, the buzzer will sound intermittently	<div style="border: 1px solid black; display: inline-block; padding: 2px;">14</div> <p style="text-align: center;">Speed</p>
NO015 Electricity measurement pattern	Electricity measurement pattern	<div style="border: 1px solid black; display: inline-block; padding: 2px;">15</div> <p style="text-align: center;">Power</p>
NO016 All type SW monitor mode	All type SW monitor mode Presser foot SW, BHSW, BW front/back SW (2SW) Bobbin winding SW If the condition of the SW changes, the buzzer will sound one time.	<div style="border: 1px solid black; display: inline-block; padding: 2px;">18</div> <p style="text-align: center;">Switch monitoring</p>
NO019 Flash memory domain deletion mode	Flash memory domain deletion Practically, clear the embroidery memory.	<div style="border: 1px solid black; display: inline-block; padding: 2px;">19</div> <p style="text-align: center;">Clearing memory</p> <div style="border: 1px solid black; display: inline-block; padding: 2px; margin-top: 10px;">OK</div>
NO022 NP sensor condition check	NP sensor condition check Check the angle of the top shaft by the buzzer: 5° -- 75°: no buzzer 75° -- 125°: buzzer sounds 125° -- 273°: no buzzer 273° -- 5°: buzzer sounds	<div style="border: 1px solid black; display: inline-block; padding: 2px;">22</div> <p style="text-align: center;">NP Sensor</p>

初期化

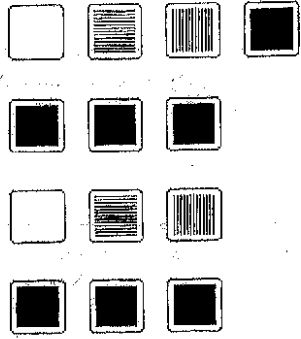
NO24 LCD check	LCD check The LCD will change to the display indicated on the button.	<div style="border: 1px solid black; padding: 5px; width: fit-content; margin-bottom: 10px;">24</div> <p style="text-align: center;">LCD Check</p> 
NO25 Tension adjustment	Refer to 40	
DS • NO30	FD drive check Install a 2HD FD and press Test1. If "GOOD" displays, it is OK. Next, install a write protected 2HD FD and press Test2. If "GOOD" displays, it is OK.	<div style="border: 1px solid black; padding: 5px; width: fit-content; margin-bottom: 10px;">30</div> <p style="text-align: center;">FDD check</p> <div style="display: flex; justify-content: space-around; align-items: center;"> <div style="text-align: center;"> <p>TEST 1</p> <div style="border: 1px solid black; padding: 2px 10px;">OK</div> </div> <div style="text-align: center;"> <p>TEST 2</p> <div style="border: 1px solid black; padding: 2px 10px;">OK</div> </div> </div>
NO40 Demo screen	Animated demo screen	

The other test modes are used for factory adjustments.

Making initial adjustments with the test modes

After the operations listed below are performed, the test modes should be used to make initial adjustments to the sewing machine.

1. When new main PC board assembly is installed:
 - * Make adjustments using test modes "2" and "3" and "25"
 - When the main PC board is replaced, upgrade the software to the newest version. (Refer to 54)
2. When the ZPM holder assembly, BH assembly or presser bar is removed or presser height is adjusted:
 - * Make adjustments using test mode "2".
3. When the FPM holder assembly or SPM holder is removed:
 - * Make adjustments using test mode "3".
4. To adjust the upper thread-tension:
 - * Be sure to adjust the tension according to test mode 25.
5. When the FDD is connected:
 - * Operate TEST mode 30.

3. TENSION OF MOTOR BELT AND TIMING BELT

STANDARD

There should be a 1.5-3.5 mm slack in the motor belt when the center of the motor belt is pressed with a force of 1N (100g).

There should be a 3-4 mm slack in the timing belt when it is pressed with a force of 2N (200g).

ADJUSTMENT

Timing belt

1. Loosen the screw of the belt adjusting pulley.
2. Adjust the position of the belt adjusting pulley.
3. Tighten the screw of the belt adjusting pulley.

Motor belt

1. Loosen the two screws securing the motor holder.
2. Adjust the belt tension by moving the motor holder.
3. Tighten the two screws.

Adjustment Points

1. If the timing belt tension is too loose, the belt may jump while sewing on denim and other thicker fabrics or overlapping fabric, or the feed timing or the closeness of the needle and rotary hook may prevent sewing.
2. If the motor belt tension is too tight, the torque becomes too much, causing the motor to rotate slower and generate an irregular noise.
3. If the motor belt tension is too loose, the belt may jump and the upper shaft may not rotate smoothly while sewing on denim and other thicker fabrics or overlapping fabrics, the motor may not rotate smoothly, or the upper shaft may not rotate.

4A-B
印字機部
4A-B
721 H011
調整
4A-B
印字機部
MT76-21

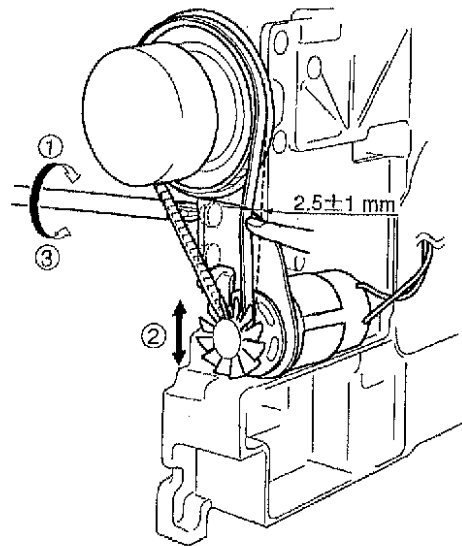
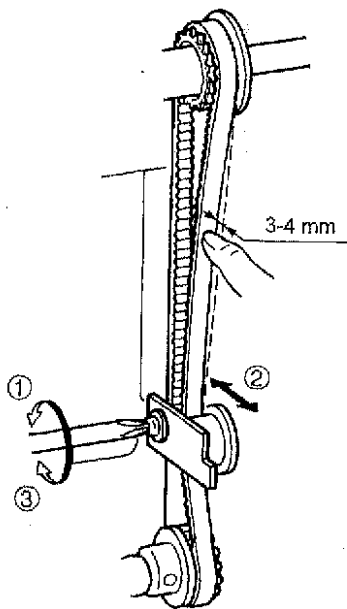

4. NEEDLE DOWN POSITION ADJUSTMENT

STANDARD

When test mode "4" is selected, the needle should be exactly at the middle of the needle plate hole in the needle down position.

ADJUSTMENT

1. Select test mode "4".
2. Turn the balance wheel to move the needle to the needle down position.
3. Loosen the screw securing the zigzag connecting rod assembly.
4. Press the keys on the display to move the needle to the left and right, and then turn the zigzag adjusting nut by using the box wrench to set the needle in the center of the needle hole.
5. Tighten the screw securing the zigzag connecting rod assembly.
6. Press the keys on the display to move the needle to the left and right and check the needle down position.

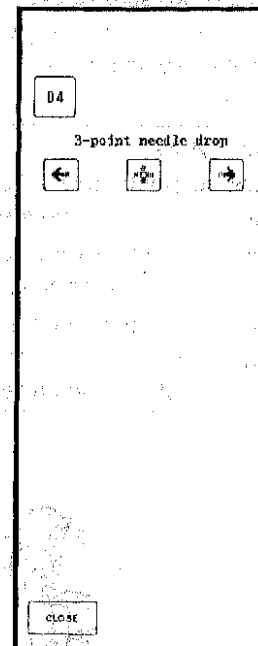
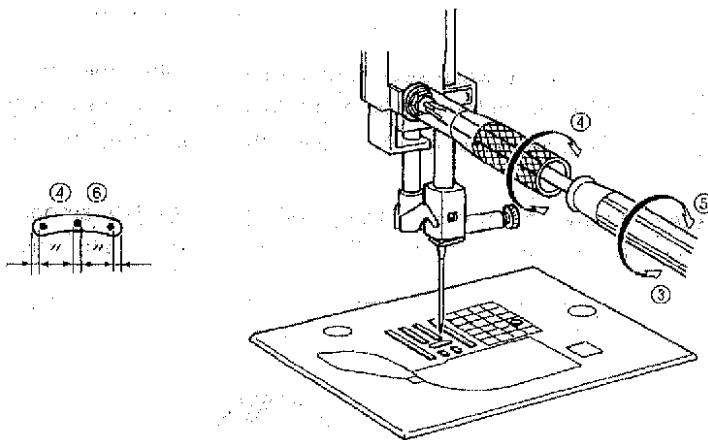

Test mode for main PC board only

(3-point needle drop, alarm check)

1. Turn on the power with the front cover removed.
2. Press the SW5 switch.

The main seam position will change each time it is pressed: left seam position → middle seam position → right seam position. L M 針差5

3. R

* Press the SW1 switch, make the feed 0, and operate at the lowest speed. SW1 = SS 停止

* By pressing the SW3 switch, the conditions will change as follows:

① Low speed (70 RPM) Feed = 0 (Original condition)

In the conditions described above, press SW5 to change the seam position without regard to the needle position:

left seam position → right seam position → left seam position ...

↓

② Medium speed (410 RPM) Feed = 0

In the conditions described above, press SW5 to change the seam position without regard to the needle position: 力加減、上下少々、

left seam position → right seam position → left seam position ... 針差も。

↓

③ High speed (850 RPM) Feed = 0

In the conditions described above, press SW5 to change the seam position without regard to the needle position:

left seam position → right seam position → left seam position ...

↓

④ High speed (710 RPM) triple zigzag Feed = Maximum (4mm), Z = Maximum (7mm) 送り音。

↓

Low speed (70 RPM) Feed = 0

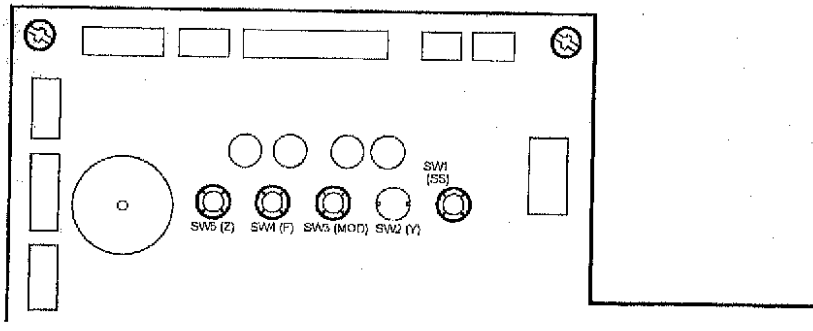

5. TIMING OF NEEDLE AND ROTARY HOOK (CLEARANCE BETWEEN THE NEEDLE AND THE ROTARY HOOK POINT)

STANDARD

When test mode "5" is selected and the needle is raised 2.9-3.3 mm from its lowest position, the rotary hook point should be positioned at the right side of the needle.

The clearance between the needle and the rotary hook point should be 0.1 mm or less, and they should never touch each other.

ADJUSTMENT

1. Select test mode "5".
2. Loosen the three screws of the lower shaft gear.
3. Adjust timing of the needle and the rotary hook. (When the needle is raised 2.9-3.3 mm from its lowest position, the rotary hook point should be positioned at the right side of the needle.)
4. Tighten the three screws of the lower shaft gear.
5. Turn the eccentric screw, and set the clearance between the needle and the rotary hook point to 0.1 mm or less. Make sure that the needle does not make contact with the rotary hook point.

Adjustment Points

1. When adjusting the timing, the needle should be at its lowest and leftmost position.
3. If the needle rises too little, skipped stitches, split thread or cut thread may occur. (Refer to (B) page 33.)
If the needle rises too much, skipped stitches, split thread or cut thread may occur due to a loop forming in the thread. (Refer to (C) page 33.)
5. If the clearance is too large, skipped stitches may occur. (Refer to (D) page 33.)
If the clearance is too small, the needle may generate an irregular noise (scraping metal sound) or the needle may break.

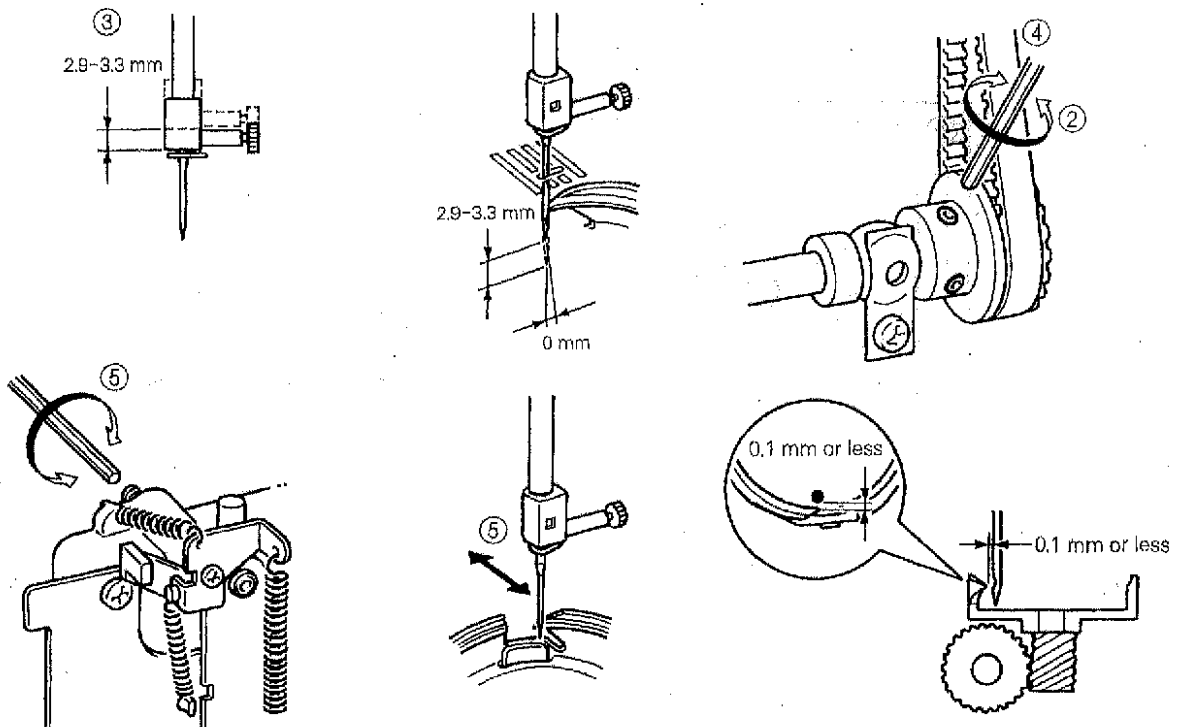

6. NEEDLE BAR HEIGHT

STANDARD

When test mode "5" is selected, turn the balance wheel so that the needle meets the rotary hook point. At this time, the clearance between the upper end of the needle eye and the bottom of the rotary hook point should be 1.0-1.4 mm.

ADJUSTMENT

1. Select test mode "5".
2. Turn the balance wheel so that the needle meets the rotary hook point.
3. Loosen the screw of the needle bar block assembly.
4. Move the needle bar vertically to adjust the clearance to between 1.0-1.4 mm.
5. Tighten the screw of the needle bar block assembly.

NOTE : The needle bar clamp should be parallel to the side of the needle plate. If the needle bar is loose when you adjust the needle bar height, it may result in sewing troubles.

Adjustment Points

1. If the needle bar height is too low or too high, skipped stitches, split thread or cut thread may occur. (Refer to (A).)
2. While adjusting the needle bar height, check the needle threading hook.

針棒高さ後
針穴糸通し

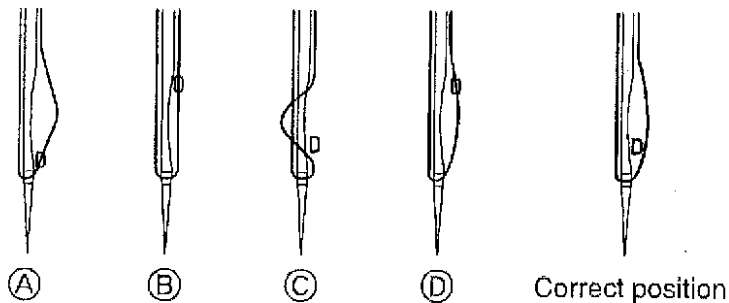
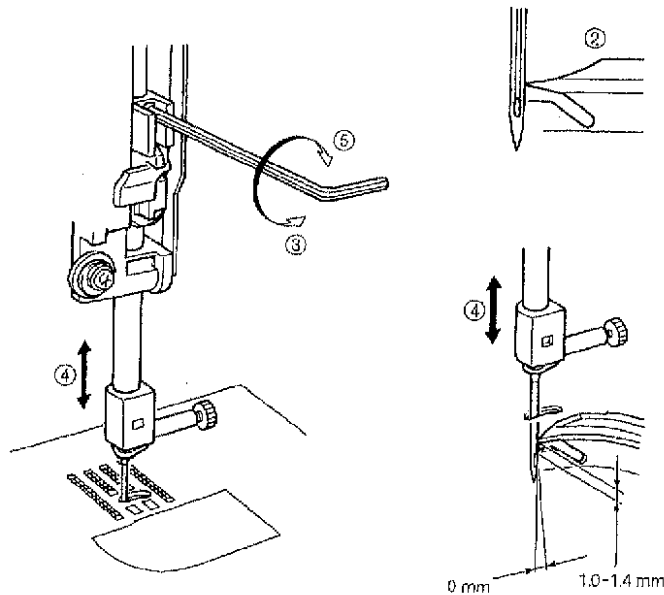

7. LOWER SHAFT

1. Attach the bushing presser L temporarily so as the center of lower shaft is positioned higher by 1 mm against the center of eccentric metal.
2. Install the outer rotary hook.
3. Tighten the screw on the bushing presser L by turning the eccentric metal. Make sure that there is no backlash on the gears.

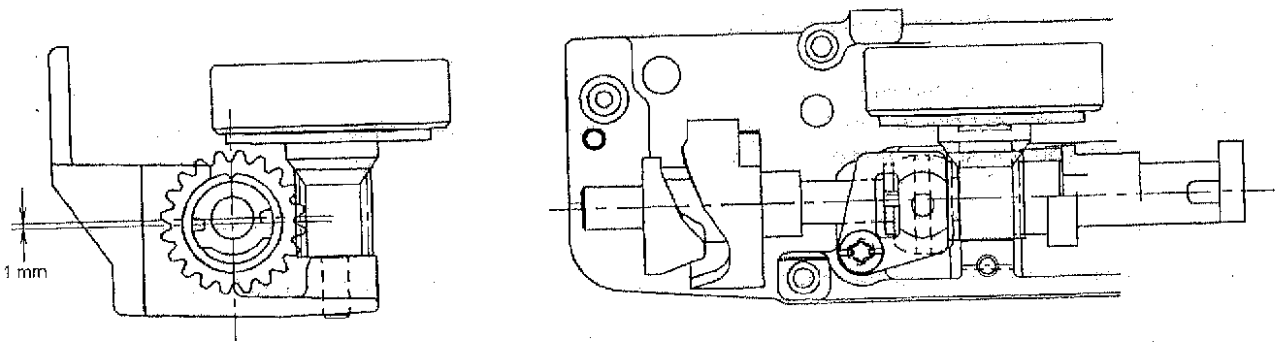

D5

8. FRONT/BACK, LEFT/RIGHT POSITION OF FEED DOG

STANDARD

When test mode "6" is selected, move the feed dog front/back and left/right. At this time, the feed dog should not contact the needle plate.

When the front/back position is the maximum feed amount, the clearance between the feed dog and needle plate at the feed start position (when feed dog is at very front) should be 0.3 to 1.2. (Refer to illustration)

ADJUSTMENT

1. Select test mode "6".
2. Loosen the screw securing the side feed linkage.
3. Align the feed dog's left / right position.
4. In the test mode, align the feed dog's left/right position.
5. Tighten the screw securing the side feed linkage.
6. After adjusting, press the thread cut button, and confirm that the thread cutter operates correctly. If the thread cutter does not operate, readjust the feed dog slightly to the back.

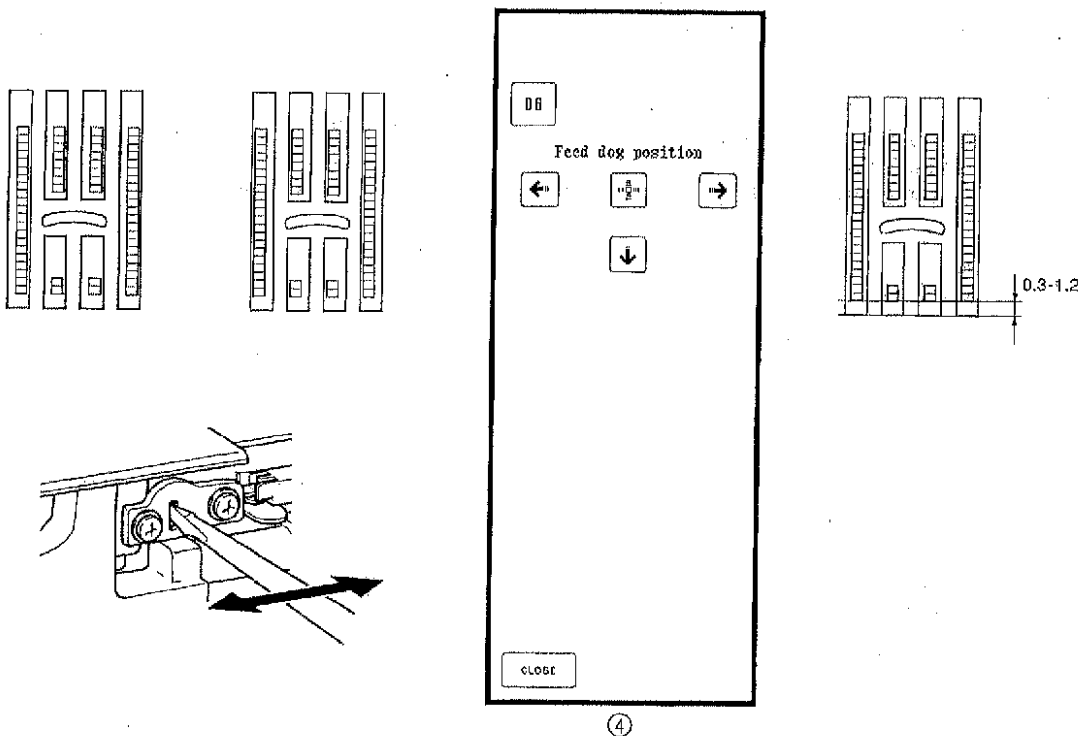

D5

Test mode for main PC board only

Feed dog position, thread cutting check

1. Turn on the power with the front cover removed.
(Disregard whether the needle is up or down and run Z, F, S, AT initialization.)
2. Press the SW4 switch.
Feed dogs = change between the left position and right position each time the switch is pressed.

Left position	10 pulses at point 1-2 left from the center (5 pulses at point 2-2)
Right position	10 pulses at point 1-2 right from the center (5 pulses at point 2-2)

NOTE) Needle position is right position
3. SW5
Feed dogs = change between the front and middle position each time the switch is pressed.

Front position	Feed 5mm
Middle position	Feed 0mm
4. Press the SW3 switch.
<When the needle is down>
 - A. Thread cutting solenoid = changes between ON/OFF each time the switch is pressed.
When ON, it will perform at a 90% efficiency of normal operation.
 - B. Operate the feed maximum/thread tension maximum actions when the thread cutting solenoid timing is OFF.

F_{max}	AT_{max}
-----------	------------

Feed maximum operation
After operating the feed to the 4mm position, operate the feed to the 5mm position.

Thread tension maximum operation
After operating to 0 on the thread tension scale, operate to the 0 position on the scale.

<When the needle is up>
Perform the maximum width operation.
After operating to the needle bar release position, operate to the rightmost position.

The pulse motor will operate at 70% power.
5. Press the SW1 switch.
Needle position = changes between the up and down position each time the switch is pressed.

SW4 = S
1-2 FB 10
2-2 FB 5

SW5 = F

90% Duty

70% Duty

SS 2/6 F
NP

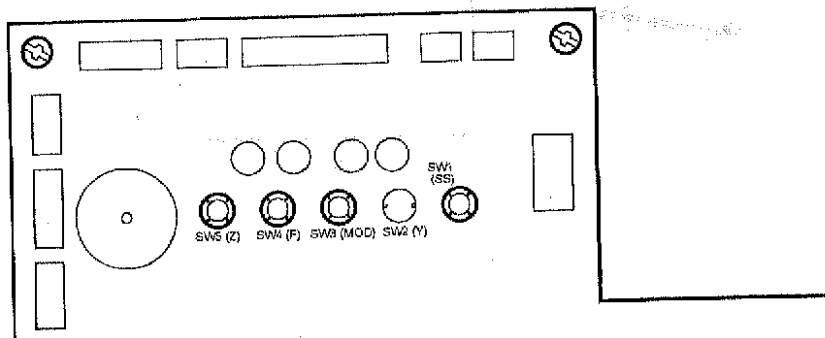

9. PRESSER BAR HEIGHT

STANDARD

The clearance from the needle plate top to the bottom of the presser bar should be 7.0-7.5 mm.

ADJUSTMENT

1. Raise the presser foot lifter.
2. Loosen the screw of the presser bar guide bracket.
3. Adjust the height of the presser bar by moving it vertically.
4. Tighten the screw of the presser bar guide bracket.

NOTE : The presser foot should be positioned in the center of the needle hole of the needle plate.

Adjustment Points

1. Install presser foot J.
2. When adjusting the presser bar height, the presser foot should be parallel with the feed dog hole in the needle plate. (Refer to (A).)
* A hexagonal pencil can be used to check the height.
3. If the presser foot is not parallel with the feed dog hole, the needle may contact the presser foot or the fabric may not feed straight while overcasting.
* After the presser bar height is adjusted, be sure to adjust the fabric thickness detector using test mode "2".

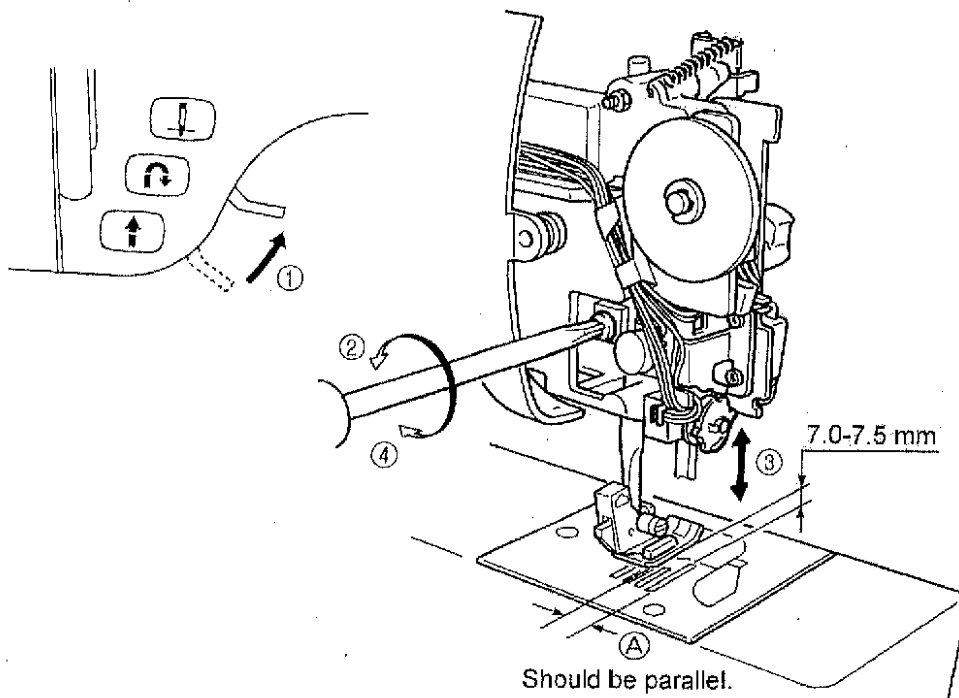

10. CHECKING DETECTION OF FABRIC THICKNESS (If a new main PC board is installed, this adjustment must be performed.)

STANDARD

When the fabric thickness is set to 0 mm and 3 mm in test mode "2", the buzzer should sound twice if operation is normal.

ADJUSTMENT

1. Select test mode "2".
2. Install the J presser foot and then lower the presser foot and set the needle bar to the lowest position.
3. Press 0 mm on the display. (The buzzer should sound twice.)
4. Insert a spacer with a thickness of 3 mm beneath the J presser foot.
5. Press 3 mm on the display. (The buzzer should sound twice.)

NOTE :If the values read in steps (3) and (5) are normal, the buzzer will sound twice each time. If they are not normal, the buzzer will sound four times each time.
If there is an abnormality, perform the procedure again starting from (2).

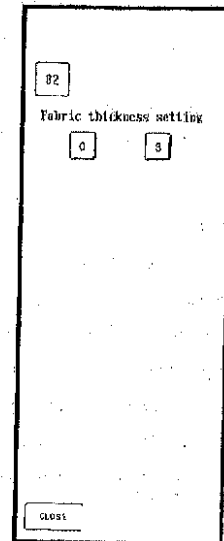

Adjustment Points

1. Be sure to install presser foot J when adjusting the fabric thickness detector.
2. If you do not have spacer when setting the thickness to 3 mm, place a 3 mm hexagonal screwdriver between presser foot J and needle plate.

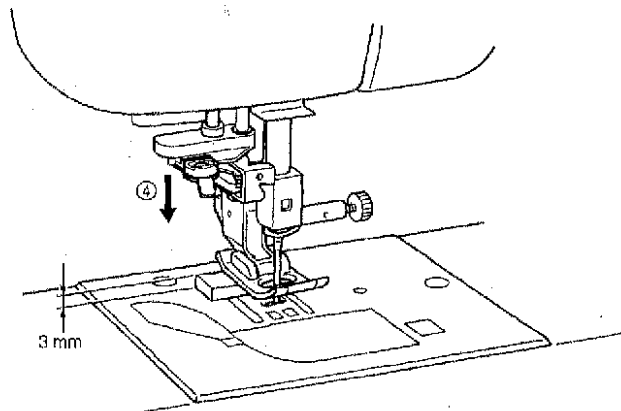
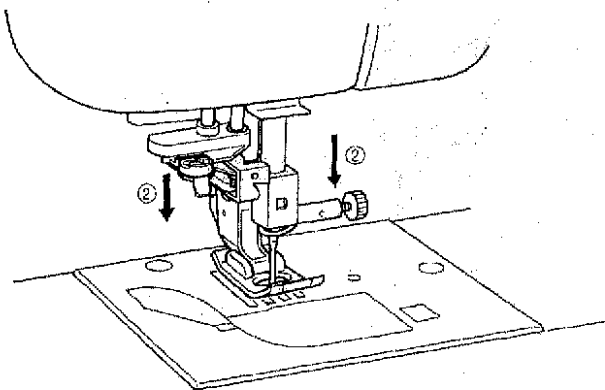

11. HEIGHT OF FEED DOG

STANDARD

When the balance wheel is turned to raise the feed dog to its highest position, the standard height of the feed dog above the needle plate should be 0.9-1.1 mm.

ADJUSTMENT

1. Turn the balance wheel to raise the feed dog to its highest position.
2. Loosen the screw securing the vertical feed roller shaft.
3. Turn the vertical feed roller shaft to adjust the feed dog height to within 0.9-1.1 mm.
4. Tighten the screw securing the vertical feed roller shaft.

Adjustment Points

1. If the feed dog is too high, the following problems may occur: the feed dog may contact the back of the needle plate, a noise may be generated, an incorrect forward and backward motion of the feed bar may be produced, an incorrect feed may be produced, or the fabric may not feed.
2. If the feed dog is too low, an incorrect feed may be produced or the fabric may not feed.

(* Check by stacking two scales, one on top of the other.)

送布高

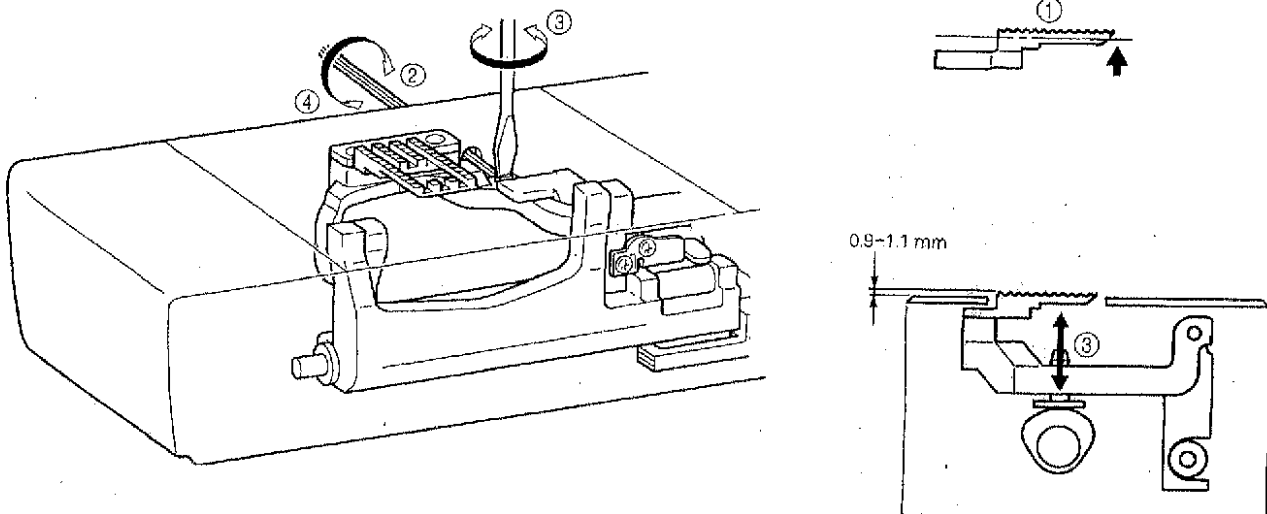

D5 AT

12. TENSION ADJUSTMENT

STANDARD

Select test mode 25.

ADJUSTMENT

1. In test mode 25.
2. Thread type: Polyester thread #60/3 plies.
Standardization: use the keys to adjust to 0.50-0.60N (50-60gf).

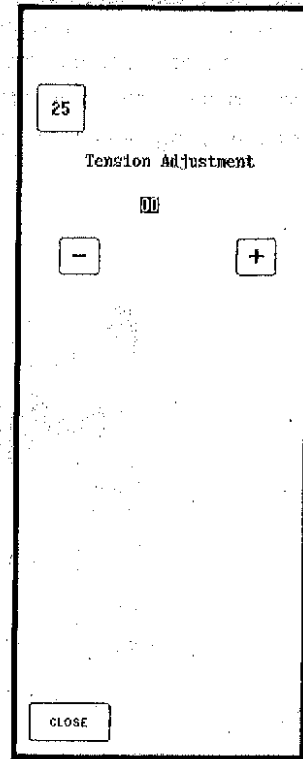
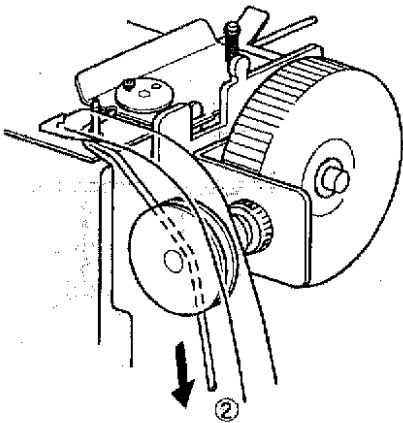
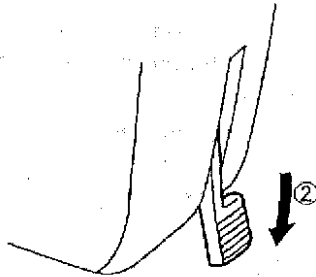

13. POSITION OF BUTTONHOLE SWITCH LEVER

STANDARD

When the buttonhole lever is lowered, the clearance of front part of buttonhole foot is 1.5 mm and the presser foot lever is lowered BH 0 should touch BH 1.

ADJUSTMENT

1. Turn on power switch and select pattern .
2. Fit the buttonhole foot (A). Adjust the clearance to 1.5 mm, and lower the presser foot lever.
3. Adjust the position of buttonhole lever so that BH0 touches BH1 when the buttonhole eccentric shaft is rotated.

NOTE :In case that the length are shorter than the standard, bend the BH 1 to be far from BH 0.
In case that the length are longer than the standard, bend the BH 2 to be close to BH 0.

Adjustment Point

If the buttonhole eccentric shaft (C) is rotated clockwise, the clearance (D) between BH0 and BH1 widens.
Pull (B) of the buttonhole foot to its maximum and check that the switch can be switched.

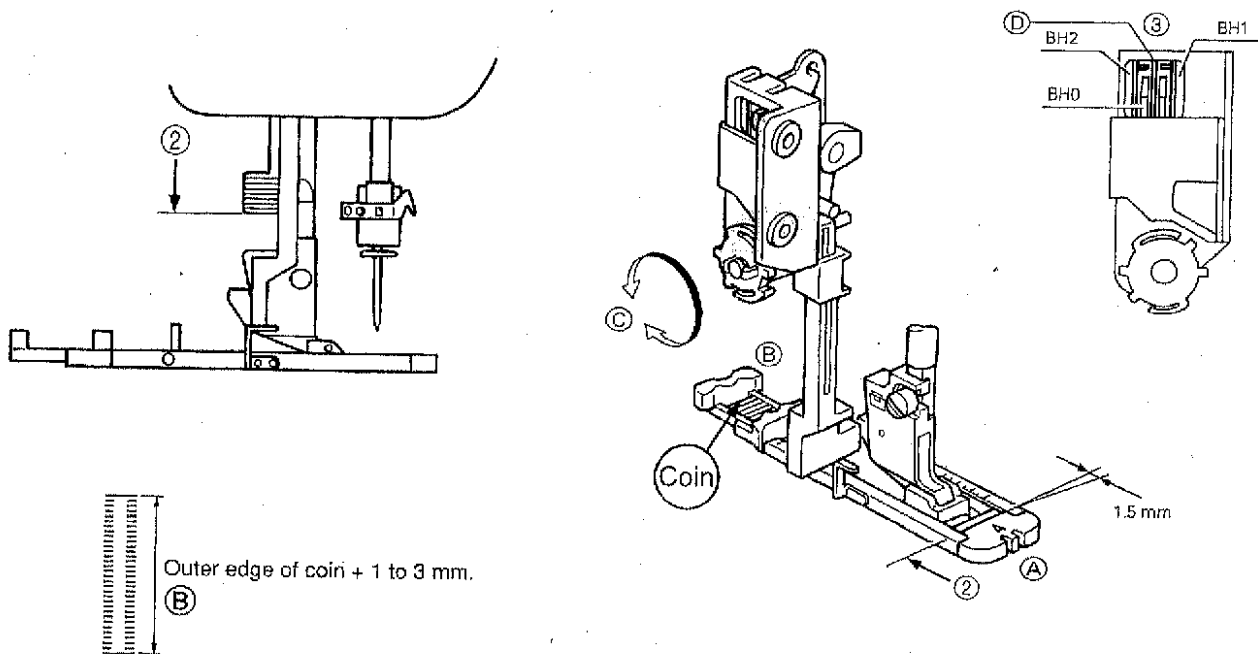

14. BOBBIN WINDER

STANDARD

The thread should be wound parallel to the bobbin and around about 85-90% of the bobbin.
The clearance between the bobbin winder switch and the bobbin winder assembly should be 0.5-1.0 mm.

ADJUSTMENT

1. Remove thread guide cover by lifting it from above.
2. Loosen the thread guide holder screw.
3. Adjust the bobbin thread amount so that the thread is evenly wound around the bobbin by moving the thread guide holder vertically.(A)
4. Tighten the thread guide holder screw.
5. Set the bobbin winder assembly to the left.
6. Loosen the screw of the bobbin winder switch.
7. Adjust the clearance between the bobbin winder switch and the bobbin winder assembly to 0.5-1.0 mm.
8. Tighten the screw of the bobbin winder switch.

Adjustment Point

3. If the thread winds as shown by (B), lower the thread guide holder (A). If the thread winds as shown by (C), raise the thread guide holder (A).

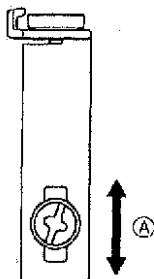

15. BOBBIN THREAD DETECTOR

STANDARD

When the amount of the bobbin thread has decreased until the bobbin diameter is 11.4-11.8 mm, the message "Bobbin thread is running out." should appear on the display.

ADJUSTMENT

1. Select test mode No.10 on the touch panel.
 2. Turn the balance wheel in its normal rotation direction, align the opening of the outer rotary hook with the photo diode, and make sure that "0.0" appears on the display.
 3. Wind the bobbin thread around the bobbin until the diameter of the bobbin is 11.4-11.8 mm, and set the bobbin in the inner rotary hook.
 4. Loosen the screw holding the photo transistor, slightly adjust the photo transistor to the left until "+.+" appears on the display. Then adjust it to the right until "0.0" appears on the display, and tighten the screw.
- NOTE :Keep the area around the photo transistor and the photo diode clean.

Remove the lamp during the adjustments.

Adjustment Points

1. Remove the needle plate before making the adjustment.
2. After aligning the opening of the outer rotary hook with the photo diode so that "0.0" appears on the display, the inner rotary hook (A) should contact the bracket while the photo transistor screw (B) is loosened and tightened so that the photo transistor can be adjusted.

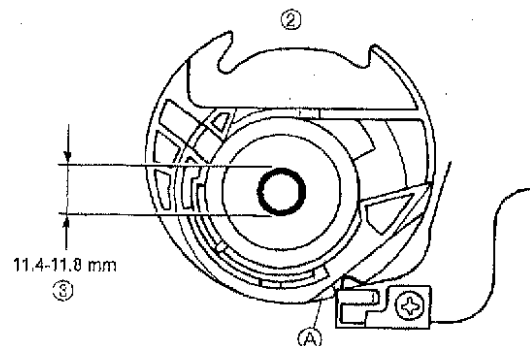
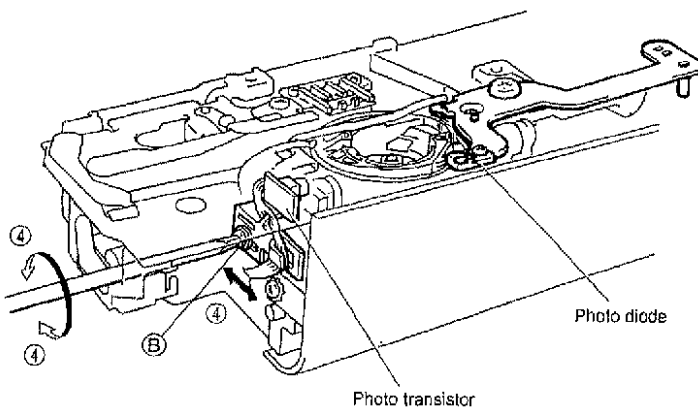

16. INNER ROTARY HOOK BRACKET POSITION

STANDARD

When the inner rotary hook bracket and the rotary hook meet, the spring of the inner rotary hook bracket and the inner rotary hook should overlap each other by 1.7 ± 0.1 mm.

ADJUSTMENT

1. Loosen the screw securing the inner rotary hook bracket.
2. Adjust the position of the inner rotary hook bracket by moving it vertically and/or horizontally.
NOTE :Surface A of the inner rotary hook bracket should be perpendicular to the feeding direction.
3. Tighten the screw of the inner rotary hook bracket.

Adjustment Point

1. If the inner rotary hook bracket position is moved by a large amount, be sure to check and adjust the bobbin thread detector with test mode "10".

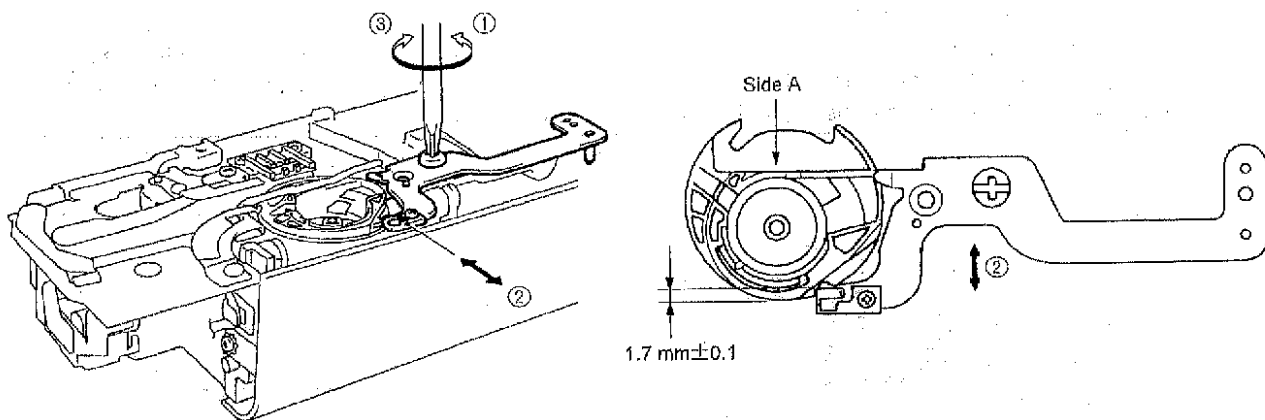

17. LARGE ONE-POINT PATTERN SHAPE (SOFT ADJUSTMENT)

STANDARD

When pattern adjustment "3" is selected in test mode and the start/stop button is pressed, the vertical and horizontal separation of the test pattern outline should be 1 mm or less.

ADJUSTMENT

1. Select "3" pattern adjustment in the test mode.
2. Press the start/stop button and sew the test pattern outline.
* Install presser foot N before sewing.
3. Adjust the pattern.

Adjustment Points

1. If the pattern is compressed in the \updownarrow direction, press the vertical \oplus button. (A)
If the pattern is stretched in the \updownarrow direction, press the vertical \ominus button. (B)
If the pattern is compressed in the \leftrightarrow direction, press the horizontal \oplus button. (C)
If the pattern is stretched in the \leftrightarrow direction, press the horizontal \ominus button. (D)
2. The should be adjusted using the four settings for each direction.
* If the pattern cannot be adjusted using the four settings for each direction, refer to FEED ADJUSTMENT (VERTICAL FEED) on page 46 and adjust the F pulse motor position.

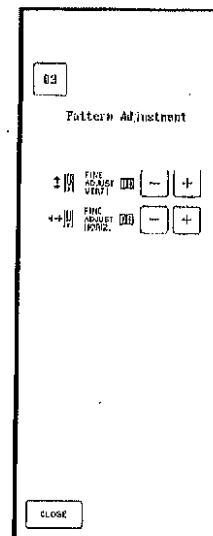
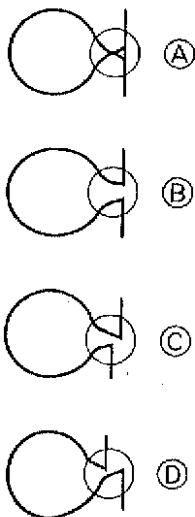

Adjustment Limits

Adjust form of edge of the tune-up pattern as seen in the following diagram.

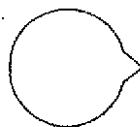

Intricate adjustments may be required for some patterns.

18. FEED ADJUSTMENT (VERTICAL FEED)

STANDARD

Adjustment of the pattern should be possible in test mode "3".

ADJUSTMENT

1. Loosen the screw securing the pulse motor.
2. Rotate the pulse motor and adjust the pattern.
 - * Make sure not to contact the main PC board during the adjustment.
 - * Install presser foot N before the adjustment.
3. Tighten the screw securing the pulse motor.

Adjustment Points

- * If the pulse motor position is to be adjusted (when the screw is to be turned or the motor is to be moved), turn off the power to the sewing machine in order to reduce the risk of a short-circuit (or damage) to the main PC board with the screwdriver.
1. If the pattern is open as shown by (E), move the pulse motor slightly backward.
 2. If the pattern is overlapping as shown by (F), move the pulse motor slightly forward.

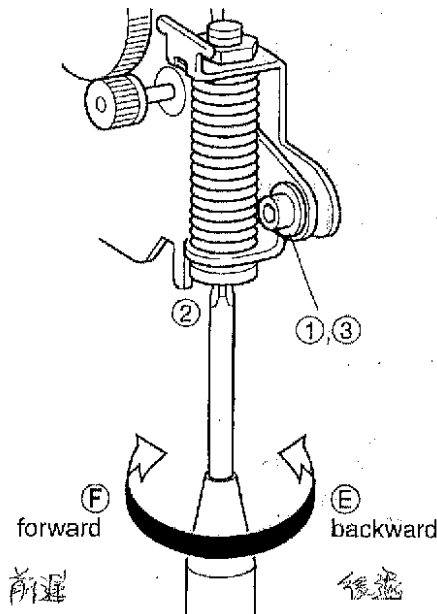
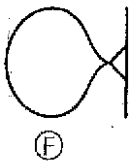
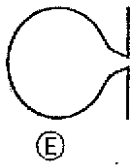

D5

19. INNER ROTARY HOOK TENSION

STANDARD

While slowly pulling polyester thread #60/3 plies using a tension gauge, inner rotary hook tension should be 0.11-0.13N (11-13g). The difference between this and the tension for silk thread (#80) should be 0.02-0.03N (2-3g).

ADJUSTMENT

1. Pass polyester thread #60 through the inner rotary hook correctly, and pull it using the tension gauge.
2. Adjust the tension by turning the screw to either the right or left using a screwdriver.

NOTE :After adjusting the tension, lock the screw with paint.

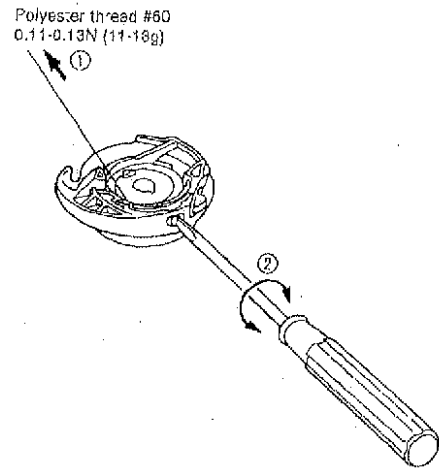

20. KNEE LIFTER

STANDARD

When 5N (500g) is applied to bend of lifter, there should be 2-3mm of space between lifter and presser holder (see (A) on diagram).

ADJUSTMENT

1. Lower presser foot. (To prevent operation of knee lever, feel free to remove it.)
2. Loosen screw.
3. Apply 5N (500g) load to bend of lift and measure amount of space between lift and presser holder (see (A) on diagram).
4. Tighten screw.

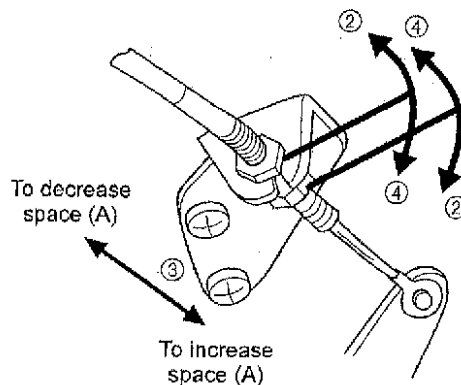
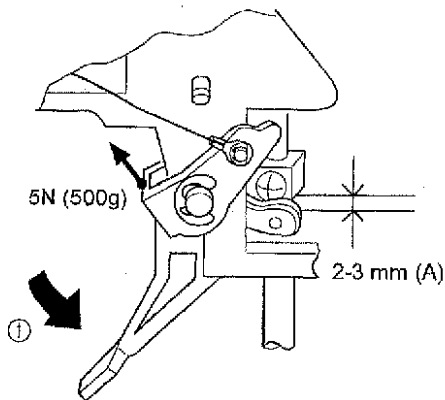

21. NEEDLE THREADER

USING THE NEEDLE THREADER

There are a wide variety of different needles and sewing machine threads available. The right ones should be selected in accordance with the sewing conditions. The accessory needle threader is designed to make threading of needles easier, but it cannot handle every single circumstance of use (combinations of needle and thread) that may occur. It can be used with some combinations but not with others, and if it can be used, the pattern may not be sewn correctly due to the particular sewing conditions. Do not use the needle threader without gaining a thorough understanding of how to use it, otherwise the needle threader may be damaged or needle threading may not be possible. Be sure to read and understand the following so that you can handle customer complaints.

NOTE :

1. Needle threader accepts only circled needle and thread combinations.
2. Combinations marked with a * are not recommended since they might lead to the breakage of needle threader performance.
3. Lower the presser foot when you use needle threader.
4. Nylon transparent thread is applicable in needle #14-16.
5. Do not turn the balance wheel when using needle threader.
6. Do not lower the needle threader lever while the machine is running. If it is lowered, the needle threader may be broken, rendering it unusable. Besides this, it may cause the needle to break, which could result in injury.
7. If a #9 needle is used, the variation in needle precision may result in the needle being slightly difficult to thread.
8. Needle should be located above needle plate by more than 8 mm for threading.
9. Needle threader does not work when you use the side-cutter.
Thread the needle before attaching the side cutter.
10. When doing embroidery, use a #11 needle. Use special weight #50 embroidery thread and #50-#80 silk thread for the embroidery thread.

Thread \ Needle	#30	#50	#60	#80	#100	#120
#9	×	×	×	○	○	○
#11	×	○	○	○	○	*
#14	×	○	○	○	*	*
#16	*	○	○	*	*	*
#18	*	*	*	*	*	*

D5

22. NEEDLE THREADER (CHECKING THE HOOK POSITION IN HORIZONTAL DIRECTION)

STANDARD

The measure from inside of the hook guard to the center point of hook is 0.42 mm.

CHECK

As sewing needle HA X1 (#14) is standard, so prepare five brand-new sewing needles HA X1 (#14) and check by changing all of these.

After Checking,

1. In case that, hook goes through eyelet of all needles There is no problem.
2. In case that, hook does not go through eyelet of all needles Adjust by bending hook.
3. In case that, hook does not go through eyelet of some needles Needles through which the hook does not go through are defective.

(Example for checking)

When you check five brand-new sewing needles HA X1 (#9) on condition that it achieves above first case, if the hook does not go through eyelet of all of these needle, all five needles are defective and you judge the hook position is not defective.

ADJUSTMENT

In case the hook is defective after above checking, adjust the hook by bending with pliers. Do not bend the hook guard at this time.

23. NEEDLE THREADER (EXCHANGE)

HOW TO REPLACE NEEDLE THREADER

1. Remove the needle and lower the presser foot lifter.
2. Lower the needle threader lever as far as possible. With the hook rotated, push down on the needle threader device to remove it. (Push down on the portion of the thread guide assembly shaded in the illustration.)
3. Place the new device so that groove S and groove T of the hook assembly and thread guide assembly are aligned with pin A, as shown in the illustration.
4. Push the needle threader device up until pin A is inserted in the grooves. (Be careful that pin B is inserted into the groove in part C.

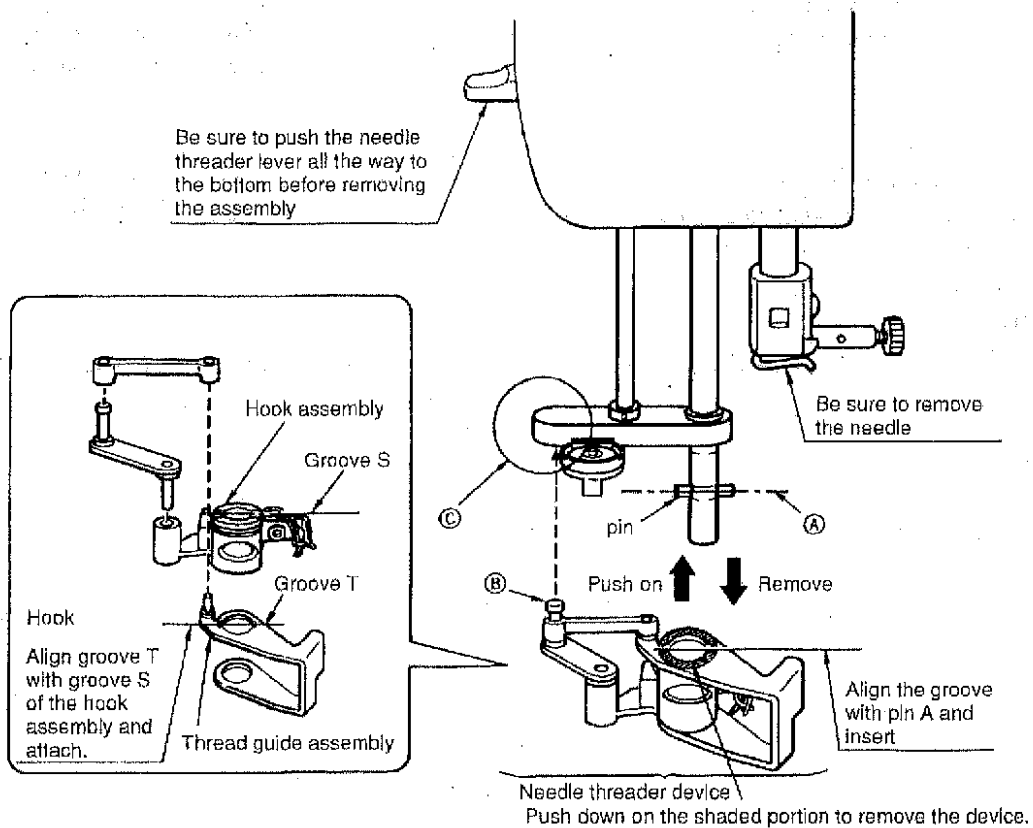

24. NEEDLE THREADER (CHECKING THE HOOK IN STANDARD POSITION)

STANDARD

1. The clearance between the top of hook and the top of needle eye is 0 mm.
2. Threading is possible when needle is located higher than 8 mm from the needle plate.

CHECK (refer to illustration)

Case A

Hook position is too high. (Hook hits needle and cannot go through needle eye.)

Case B

Hook position is too low. (Hook goes through needle eye but it catches bottom part of needle eye.)

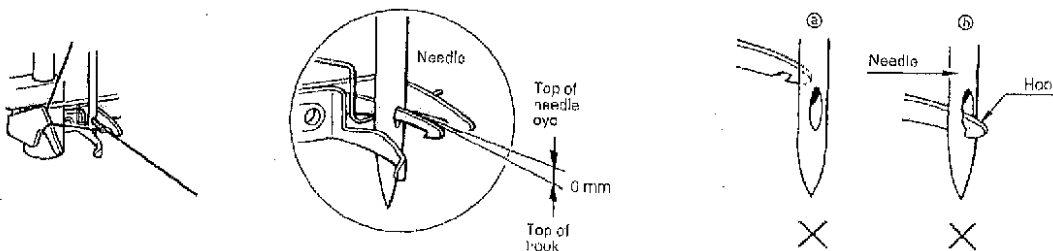

25. NEEDLE THREADER (CHECKING THE HOOK POSITION IN VERTICAL DIRECTION)

Case A (Hook point is too high)

1. Remove face plate and loosen the screw.
2. Adjust needle threader position setter slightly down and check that the clearance between the top of hook and top of needle eye is 0 mm.
3. Check that the needle threader position setter (a) and the needle bar crank rod assembly (b) is parallel.

Case B (Hook point is too low)

Adjust needle threader position setter slightly up and check the clearance between the top of hook and top of needle eye is 0 mm. In case part (a) and part (b) is not parallel or the hook does not work, readjust needle threader by loosening the screw.

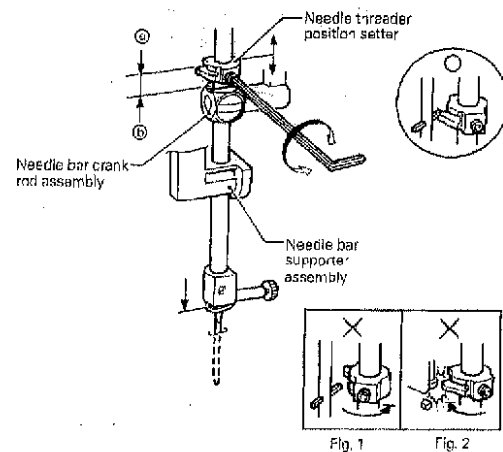

If (a) and (b) are not parallel, the needle threader will not be held by the needle threader position setter (refer to Fig. 1), the hook will not enter the eyelet of the needle (hook will not move) and the needle will not be threaded when the needle threader lever is lowered. In this case, loosen the screw securing the needle threader position setter and turn the needle threader position setter slightly to the left to make it parallel.

In addition, if the needle threader position setter is turned too far so that it is still not parallel too left, it may hit other parts, causing damage (refer to Fig. 2). If a part is damaged, it must be replaced.

If no part is damaged, loosen the screw securing the needle threader position setter and turn the needle threader position setter slightly to the right to make it parallel.

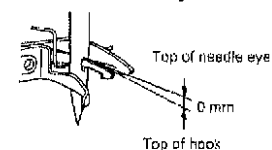

EMBROIDERY UNIT ADJUSTMENTS

26. TIMING BELT TENSION FOR THE X DIRECTION

STANDARD

There should be 4 mm slack in the timing belt looped around the X driving shaft and the X tension pulley shaft, when the center of the belt is pressed by a force of $1.2 \pm 0.12\text{N}$ ($120 \pm 40\text{g}$) after the X carriage unit is moved all the way to the right.

150 ~ 180 g

ADJUSTMENT

1. Move the X carriage unit all the way to the right.
2. Loosen the screw of the X tension pulley.(screws (A) and (B))
3. Adjust the position of the X tension pulley.
4. Tighten the screw of the X tension pulley.(screws (A) and (B))

Adjustment Point

If the tension in the belt is too weak or too tight, the embroidery may not be aligned correctly (the inside of the pattern may not align with the outline).

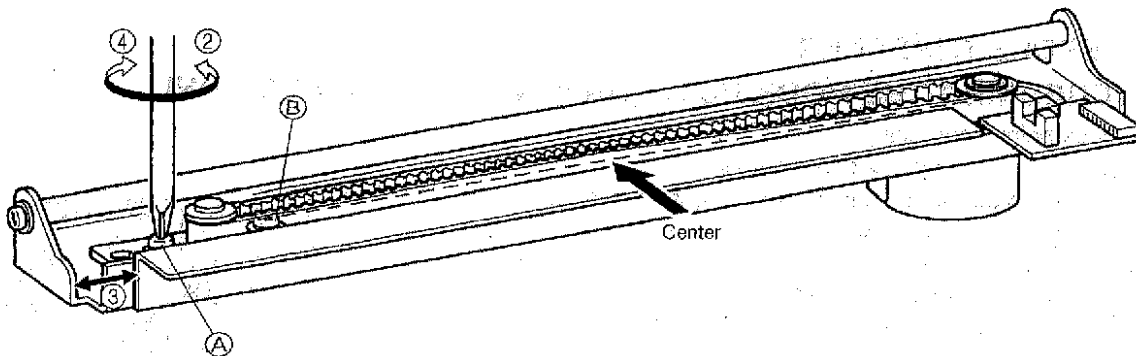

27. TIMING BELT TENSION FOR THE Y DIRECTION

STANDARD

There should be 8 mm slack in the timing belt when the center of timing belt at the Y drive shaft and Y tension pulley is pressed with a force of $1.2 \pm 0.12\text{N}$ ($120 \pm 10\text{g}$) after the Y carriage is moved all the way forward.

150 ÷ 180g

ADJUSTMENT

1. Move the Y carriage all the way forward.
2. Loosen the screw of the Y tension pulley.(screw (C) and (D))
3. Adjust the position of the Y tension pulley.
4. Tighten the screw of the Y tension pulley.(screw (C) and (D))

Adjustment Point

If the tension in the belt is too weak or too tight, the embroidery may not be aligned correctly (the inside of the pattern may not align with the outline).

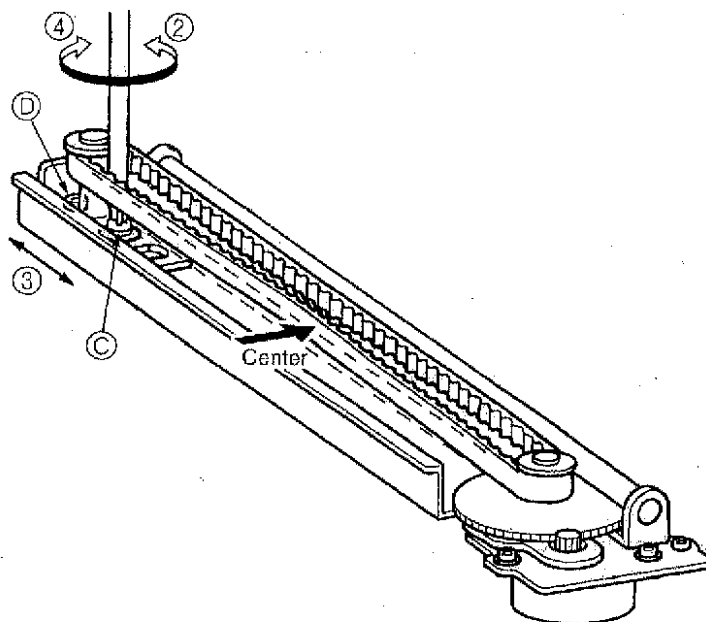

D5

Version UP

28. FD UPGRADE PROCEDURE

Operations on the Sewing Machine

1. Hold down the bobbin winding button while turning on the machine. After 5 seconds, release the bobbin winding button.

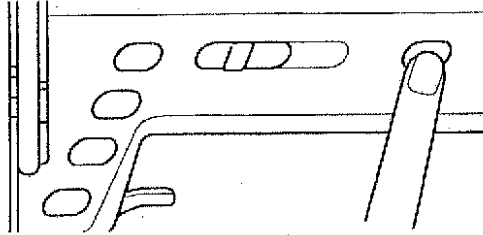

The following message will appear on the LCD, and the machine will be in UPGRADE mode.

Display: UPGRADES AND UPDATES INSERT FLOPPY DISK NO1 AND PRESS THE BOBBIN WINDING START/STOP BUTTON.

2. Insert the floppy disk with PROGRAM1.UPG and press the bobbin winding button again.

Display: LOADING FLOPPY DISK NO1

When the data is finished loading, the display will change as shown below.

Display: INSERT FLOPPY DISK NO2 AND PRESS THE BOBBIN WINDING START/STOP BUTTON

Insert the floppy disk with PROGRAM2.UPG and press the bobbin winding button again.

Display: LOADING FLOPPY DISK NO2

When the data is finished loading, the display will change as shown below.

Display: INSERT FLOPPY DISK NO3 AND PRESS THE BOBBIN WINDING START/STOP BUTTON

Insert the floppy disk with PROGRAM3.UPG and press the bobbin winding button again.

Display: LOADING FLOPPY DISK NO3

When the data is finished loading, the display will change as shown below.

Display: INSERT FLOPPY DISK NO4 AND PRESS THE BOBBIN WINDING START/STOP BUTTON

Insert the floppy disk with PROGRAM4.UPG and press the bobbin winding button again.

Display: LOADING FLOPPY DISK NO4

When the data is finished loading, the display will change as shown below.

Display: PROGRAM WRITING NOW

(This message will be shown for about 1 minute. Do not turn off the machine during this time. Otherwise, the machine may not operate correctly.)

When the program is finished writing, the display will change as shown below.

Display: THANK YOU COMPLETE. TURN THE POWER OFF AND BACK ON AGAIN ONCE MORE.

Caution: If all the Upgrade files are not inserted correctly, the machine will not operate correctly. If a mistake in the procedure is made, start again from the beginning.

IV. HOW TO ADJUST ELECTRONIC ELEMENTS

1. When power is turned on, buzzer does not sound and nothing appears on display	56
2. After the power is turned on, pulse motors do not return to their home positions with respect to the needle position. (Zigzag pulse motor when needle bar is raised and feed and horizontal feed pulse motors when needle bar is lowered.).....	56
3. Pattern cannot be selected	56
4. LCD does not operate correctly. Display does not light up.....	56
5. Main motor does not operate	56
6. Operation of main motor is not stable, maximum speed operation is not possible, or speed cannot be adjusted	57
7. Correct patterns are not created	57
8. Buttonholes are not stitched correctly	57
9. Manual operation of feed and zigzag pulse motors is not possible	57
10. Vertical movement of needle bar and backstitch operation are abnormal.....	57
11. Foot controller does not operate normally when depressed	57
12. Thread tension is not correct	58
13. Needle bar release mechanism does not operate correctly	58
14. Thread cutter does not operate correctly.....	58
15. Thread can not be wound around bobbin	58
16. Needle thread breakage detector does not operate correctly.....	58
17. Bobbin thread detector does not operate correctly	58
18. Embroidery unit does not operate	58
19. Embroidery unit does not work correctly.....	59
20. Embroidery frame detector does not operate correctly.....	59
21. FDD does not operate correctly	59

* You must turn off the power and remove connectors from printed circuit boards before measuring resistance.

PROBLEM	CHECK	REMEDY
1. When power is turned on, buzzer does not sound and nothing appears on display.	<ol style="list-style-type: none"> 1) Has the display contrast been adjusted? 2) Is the voltage between the AC inlet connectors (CN2 on the power supply unit) 1 – 2 standard (120 V, 230 V)? 3) Is a fuse blown? 4) Remove connector from power supply board (CN6 of the main PC board), and check the following voltages: Between 9-8: DC 26V Between 10-8: DC 12V Between 4-7: DC 5V Between 5-7: DC 3.3V Between 6-7: DC 2V 5) When the connectors (CN2 and CN3 on the main PC board) are removed from the LCD unit and the power is turned on, does the buzzer sound? 6) Others 	<ol style="list-style-type: none"> 1) Adjust the contrast. 2) Replace the inlet assembly. 3) Replace the fuse after correcting defect that caused fuse to blow. 4) Replace the power supply unit assembly. 5) Replace the card PC board assembly. 6) Replace the main PC board assembly.
2. After the power is turned on, pulse motors do not return to their home positions with respect to the needle position. (When needle is up, it is zigzag/ thread tension, when needle is down it is feed/ horizontal feed/ thread tension.)	<ol style="list-style-type: none"> 1) Are the resistance values between the connectors of pulse motors that do not return to the home position between 5 – 8 Ω? Zigzag (CN 14 on main PC board): pins 1-2, 3-4 Feed (CN 17 on main PC board): pins 1-2, 3-4 Horizontal feed (CN 20 on main PC board): pins 1-2, 3-4 Thread tension (CN 12 on main PC board): pins 1-2, 3-4 2) Set the home position for the same pulse motors irrespective of needle position. 3) Remove connector from power supply board (CN6 of the main PC board), and check the following voltages: Between 9-8: DC 26V 4) Others 	<ol style="list-style-type: none"> 1) Replace the pulse motor which shows an abnormality. 2) Replace NP board assembly. 3) Replace power supply unit assembly. 4) Replace main PC board assembly.
3. Pattern can not be selected.	<ol style="list-style-type: none"> 1) Does switch on SS (VR) PC board remain pressed? 2) When the foot controller is connected, does it remain depressed? 3) Is the touch panel adjusted? 4) Others 	<ol style="list-style-type: none"> 1) Adjust or replace SS (VR) PC board assembly. 2) Check the foot controller. 3) Adjust or replace the touch panel. 4) Replace the main PC board assembly or the card PC board assembly.
4. LCD does not operate correctly. Display does not light up.	<ol style="list-style-type: none"> 1) Remove connector from power supply board (CN6 of the main PC board), and check the following voltages: Between 10-8: DC 12V 2) Is the voltage of the inverter connector (CN2 on the card PC board) DC 12 V between points 3-2? Is the voltage DC 0 V between pins 1-2? 3) Other 	<ol style="list-style-type: none"> 1) Replace the power supply unit assembly. 2) Replace the main PC board assembly or the card PC board assembly. 3) Replace the inverter or the LCD module.
5. Main motor does not operate.	<ol style="list-style-type: none"> 1) Does the balance wheel turn easily? 2) Is the resistance between the ends of the main motor connector (CN6 on the power supply unit) between 1.5 Ω and 3.5 Ω? 3) Is a fuse blown on the main power unit? 4) Are the Start/Stop button, Reverse/Reinforcement stitch button, Needle position button, and thread cutter button correct? Resistance between ends of each button: When button is pressed: 1 Ω or less. When button is not pressed: ∞ 5) Is the presser foot lever down, or is the voltage between pins 2-1 on the connector for the fabric thickness detector (CN9 on the main PC board) DC 1V when the presser foot is down and DC 2.5V when the presser foot is up? 6) Others 	<ol style="list-style-type: none"> 1) Adjust the assembly. 2) Replace the main motor. 3) Replace the fuse after correcting defect that caused fuse to blow. 4) Replace the SS PC board. 5) Check the assembly, or replace the fabric thickness sensor. 6) Replace the main PC board, the power supply unit, or the card PC board.

6. Operation of main motor is not stable, maximum speed operation is not possible, or speed cannot be adjusted.	<ol style="list-style-type: none"> 1) When moving the speed slide, does the voltage between pins 4-2 on the VR PC board connector (CN 8 on the card PC board) change between DC 0V and DC 3.3V? 2) Does the voltage between pins 1-6, 4-6, 5-6 on the NP PC board connector (CN8 on the main PC board) change between DC 0V and DC 5V for each? Also, does the voltage between pins 2-6 change between DC 0V and DC 3.3V? 3) Others 	<ol style="list-style-type: none"> 1) Replace the VR PC board assembly. 2) Replace the NP PC board assembly. 3) Replace the main PC board, the power supply unit, or the card PC board.
7. Correct patterns are not created.	<ol style="list-style-type: none"> 1) If the power is turned off and the needle bar is moved horizontally by hand, does it move easily? 2) Is the NP shutter in the correct position? 3) Are the resistances between the connector pins for the pulse motors shown below between 5-8 Ω? Zigzag (CN14 on main PC board) 1-2, 3-4 Feed (CN17 on main PC board) 1-2, 3-4 Horizontal feed (CN20 on main PC board) 1-2, 3-4 4) When the machine is slowly operated, does the voltage between pins 1-6, 4-6, 5-6 on the NP PC board connector (CN8 on the main PC board) change between DC 0V and DC 5V for each? 5) Others 	<ol style="list-style-type: none"> 1) Adjust the assembly. 2) Adjust 3) Replace the pulse motor which shows an abnormality. 4) Replace the NP PC board assembly. 5) Replace the main PC board assembly.
8. Buttonholes are not stitched correctly.	<ol style="list-style-type: none"> 1) Is the presser foot correct? 2) Is the resistance between pins 4-5 on the BH switch connector (CN10 on main PC board) correct? BH lever down: 1 Ω or less BH lever up: ∞ 3) Is the resistance for the BH switch connector (CN10 on main PC board) pins correct? BH lever pulled to the front Between 1-2: 1 Ω or less Between 2-3: ∞ BH lever pushed to the back Between 1-2: ∞ Between 2-3: 1 Ω or less 4) Others 	<ol style="list-style-type: none"> 1) Check 2) Adjust the assembly or replace the BH switch assembly. 3) Adjust the assembly or replace the BH switch assembly. 4) Replace the main PC board assembly.
9. Manual operation of feed and zigzag pulse motors is not possible.	<ol style="list-style-type: none"> 1) Do manual keys of feed and zigzag pulse motors turn off and on normally, and do the LCD's change? 2) Are the resistances of the pins of the feed and zigzag pulse motors shown below between 5 - 8 Ω? Zigzag (CN 14 on main PC board) 1-2, 3-4 Feed (CN 17 on main PC board) 1-2, 3-4 3) Others 	<ol style="list-style-type: none"> 1) Adjust or replace the touch panel. 2) Replace the pulse motor that shows an abnormality. 3) Replace the main PC board assembly.
10. Vertical movement of needle bar and backstitch operation are abnormal.	<ol style="list-style-type: none"> 1) Are the Start/Stop button, Reverse/Reinforcement stitch button, Needle position button, and thread cutter button correct? Resistance between ends of each button: When button is pressed: 1 Ω or less. When button is not pressed: ∞ 2) Is the NP shutter in the correct position? 3) Does the voltage between pins 1-6, 4-6, 5-6 on the NP PC board connector (CN8 on the main PC board) change between DC 0V and DC 5V for each? Also, does the voltage between pins 2-6 change between DC 0V and DC 3.3V? 4) Is the bobbin winding switch turned off? 5) Others. 	<ol style="list-style-type: none"> 1) Replace the SS PC board assembly. 2) Adjust. 3) Replace the NP PC board assembly. 4) Adjust the assembly. 5) Replace the main PC board assembly.
11. Foot controller does not operate normally when depressed.	<ol style="list-style-type: none"> 1) Is the resistance between pins 2-3 of the foot controller connector (CN1 on the card PC board) ∞ when the foot controller jack is inserted, and less than 1 Ω when the jack is not inserted? 2) Does the resistance between pins 1-3 on the foot controller connector (CN1 on the card PC board) change between a few Ω and 10K Ω, depending on how deeply the foot controller is depressed? 3) Others. 	<ol style="list-style-type: none"> 1) Replace the jack assembly. 2) Replace the foot controller. 3) Replace the main PC board assembly or the card PC board assembly.

12. Thread tension is not correct.	<ol style="list-style-type: none"> 1) Is thread route correct? 2) Were adjustments made for fabric thickness? 3) Is the resistance for the pins on the thread tension pulse motor connector listed below between 5 – 8 Ω? Thread tension (CN12 on main PC board) Between 1-2, 3-4 4) Is the voltage between pins 2-1 of the fabric thickness detector (CN9 on main PC board) about DC 1V when the presser foot is down and about DC 2.5 V when the presser foot is up? 5) Others. 	<ol style="list-style-type: none"> 1) Check. 2) Check the fabric thickness adjustment. 3) Replace the AT pulse motor. 4) Check the assembly or replace the fabric thickness sensor assembly. 5) Replace the main PC board assembly.
13. Needle bar release mechanism does not operate correctly.	<ol style="list-style-type: none"> 1) Does the needle bar release move easily? 2) Is the resistance for the pins of the zigzag pulse motor shown below between 5 – 8 Ω? Zigzag (CN14 on main PC board): pins 1-2, 3-4 3) Other 	<ol style="list-style-type: none"> 1) Adjust the assembly. 2) Replace the Z pulse motor. 3) Replace the main PC board assembly.
14. Thread cutter does not operate correctly.	<ol style="list-style-type: none"> 1) Does the thread cutter move lightly? 2) Is the resistance between pins 1-2 of the thread cutter solenoid connector (CN 16 on main PC board) between 17 Ω - 22 Ω? 3) Others 	<ol style="list-style-type: none"> 1) Adjust the assembly. 2) Replace the thread cutter solenoid. 3) Replace the main PC board assembly.
15. Thread can not be wound around the bobbin.	<ol style="list-style-type: none"> 1) Is the resistance between pins 1-2 of the bobbin winder switch connector (CN5 on main PC board) 1 Ω or less when the bobbin is winding, and ∞ when the bobbin is not winding? 2) Is the resistance between pins 1-2 of the bobbin winding motor connector (CN4 on the main PC board) between 40 Ω - 70 Ω? 3) Is the resistance between both ends of the bobbin winder button on the VR PC board 1 Ω or less when the button is pressed, and ∞ when the button is not pressed? 4) Others 	<ol style="list-style-type: none"> 1) Adjust the assembly or replace the bobbin winding switch assembly. 2) Replace the bobbin winding motor. 3) Check the assembly or replace the VR PC board assembly. 4) Replace the main PC board assembly or the card PC board assembly.
16. Needle thread breakage detector does not operate correctly.	<ol style="list-style-type: none"> 1) When the upper threading is completed, is the voltage between pins 2-1 of the upper thread detector's connector (CN11 on main PC board) correct? When thread is tensioned: DC 0V When thread is loose: DC 3.3V 2) Others 	<ol style="list-style-type: none"> 1) Adjust the thread take up spring or replace the thread breakage detecting PC board. 2) Replace the main PC board assembly.
17. Bobbin thread detector does not operate correctly.	<ol style="list-style-type: none"> 1) Is the bobbin thread detection sensor assembly adjusted correctly? 2) Is the voltage between pins 1-2 of the bobbin thread detection connector (CN19 on main PC board) about DC 1V? 3) Is the voltage between pins 2-1 of the bobbin thread detection connector (CN 18 on the main PC board) correct? When an empty bobbin is inserted: DC 0.2V or less When a wound bobbin is inserted: DC 1.3 V – DC 3.3V 4) Other 	<ol style="list-style-type: none"> 1) Adjust. 2) Replace the photo diode assembly. 3) Replace the photo transistor assembly. 4) Replace the main PC board assembly.
18. Embroidery unit does not operate.	<ol style="list-style-type: none"> 1) Is the resistance between pins 5-2 on the X sensor board connector CN1 at a value of 1 Ω or less? 2) When the embroidery unit is attached to the machine, is the resistance between pins 5-2 on the embroidery unit attachment connector (CN21 on the main PC board) at a value of 1 Ω or less? 3) Others. 	<ol style="list-style-type: none"> 1) Replace the X sensor PC board assembly. 2) Replace the lead wires for the sewing machine or for the embroidery unit. 3) Replace the main PC board assembly.

<p>19. Embroidery unit does not work correctly.</p>	<ol style="list-style-type: none"> 1) Is your card a embroidery card? Is the embroidery unit connected to sewing machine correctly? 2) Is embroidery unit installed in sewing machine correctly? Are timing belt tension, gear meshing, and wiring correct? 3) Do the embroidery unit or sewing machine connectors have a malfunction? 4) Is the resistance between pins 1-2 and 3-4 of the X pulse motor connector (in the embroidery unit) 5 Ω - 7 Ω? 5) Is the resistance between pins 1-2 and 3-4 of the Y pulse motor connector (in the embroidery unit) 9 Ω - 11 Ω? 6) When the embroidery unit is attached to the sewing machine, are pins 1-2, 3-4 of the embroidery unit attachment connector (CN22 on main PC board) between 9 Ω - 11 Ω? Are pins 5-6, 7-8 between 5 Ω - 7 Ω? 7) Does a malfunction occur in the initialization when the power is turned on? 8) Others. 	<ol style="list-style-type: none"> 1) Check. 2) Adjust the torque of the embroidery frame's movement. 3) After checking, replace the lead wires of the sewing machine or of the embroidery unit. 4) Replace the X pulse motor. 5) Replace the Y pulse motor. 6) Replace the lead wires of the sewing machine or of the embroidery unit. 7) Replace the X sensor PC board or the Y sensor PC board. 8) Replace the main PC board assembly.
<p>20. Embroidery frame detector does not operate correctly.</p>	<ol style="list-style-type: none"> 1) Is each switch of the frame detection board operating correctly? When on: 1 Ω or less. When off: ∞ 2) Is the resistance between pins 4-3, 2-3, and 1-3 of CN2 on the X sensor PC board changing correctly according to the operation of each frame detection switch? When on: 1 Ω or less. When off: ∞ 3) Is the resistance between pins 7-2, 8-2, and 9-2 of CN1 on the X sensor PC board changing correctly according to the operation of each frame detection switch? When on: 1 Ω or less. When off: ∞ 4) When the embroidery unit is attached to the sewing machine, is the resistance between pins 7-2, 8-2, and 9-2 of the embroidery unit attachment connector (CN21 on the main PC board) changing correctly according to the operation of each frame detection switch? When on: 1 Ω or less. When off: ∞ 5) Others. 	<ol style="list-style-type: none"> 1) Adjust the assembly or replace the frame detection board assembly. 2) Replace the frame detection connection FFC. 3) Replace the X sensor PC board assembly. 4) Replace the lead wires for the sewing machine or for the embroidery unit. 5) Replace the main PC board assembly.
<p>21. FDD does not operate correctly.</p>	<ol style="list-style-type: none"> 1) In the test mode, is the FDD being checked? 2) Is the disk properly formatted? 3) Is the disk 2HD? 4) Is the disk scratched or damaged? 5) Others. 	<ol style="list-style-type: none"> 1) Run the check for FDD in the test mode. 2) Format the disk. 3) Check 4) Check 5) Replace the FDD or the main PC board assembly.

Main PC board

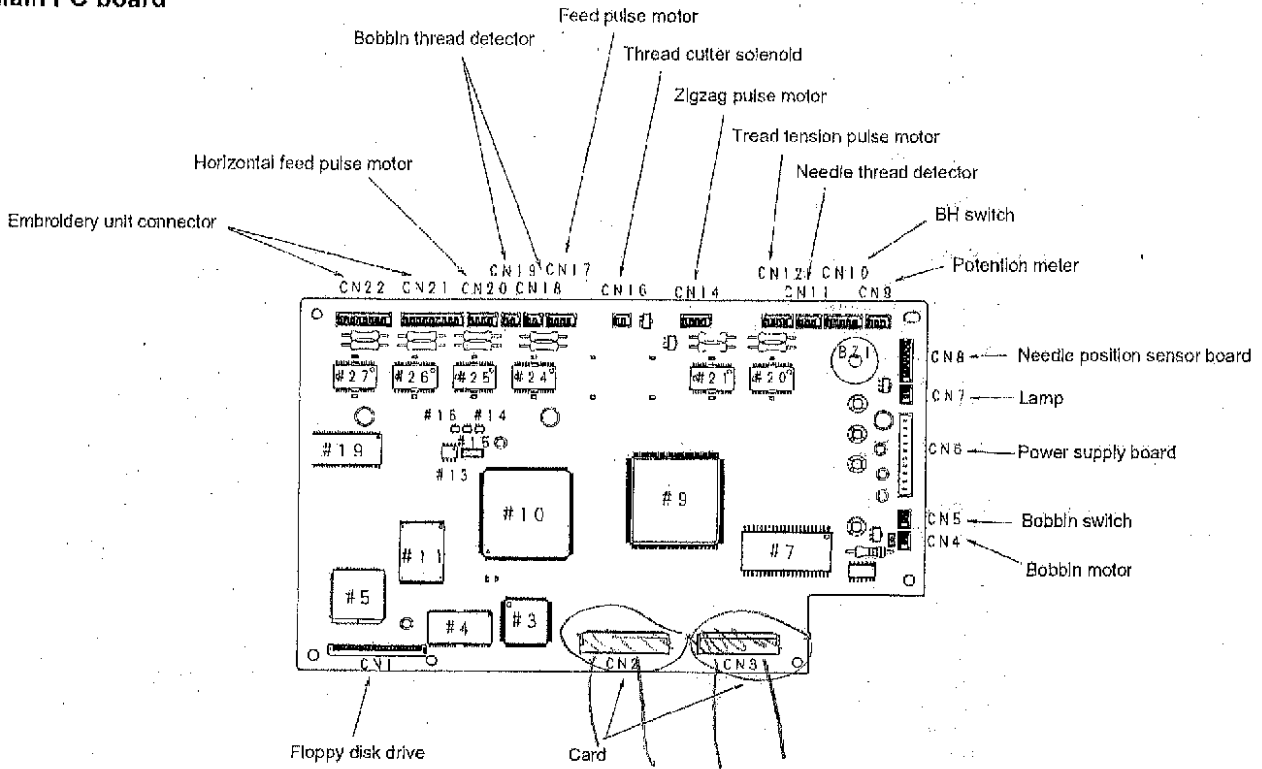

Power supply unit

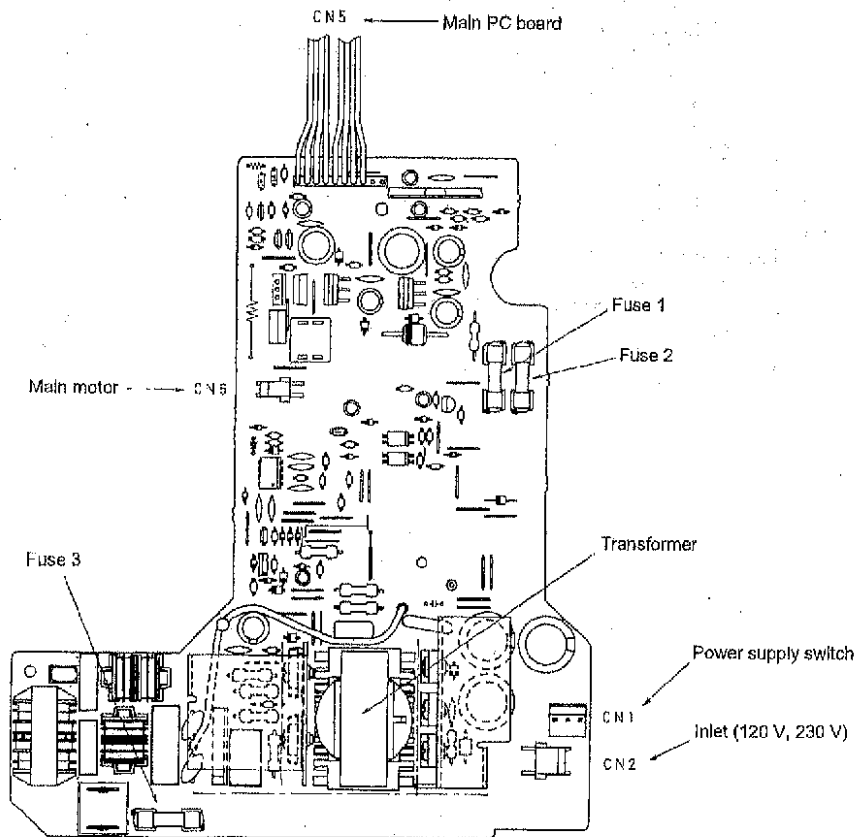

Card PC board

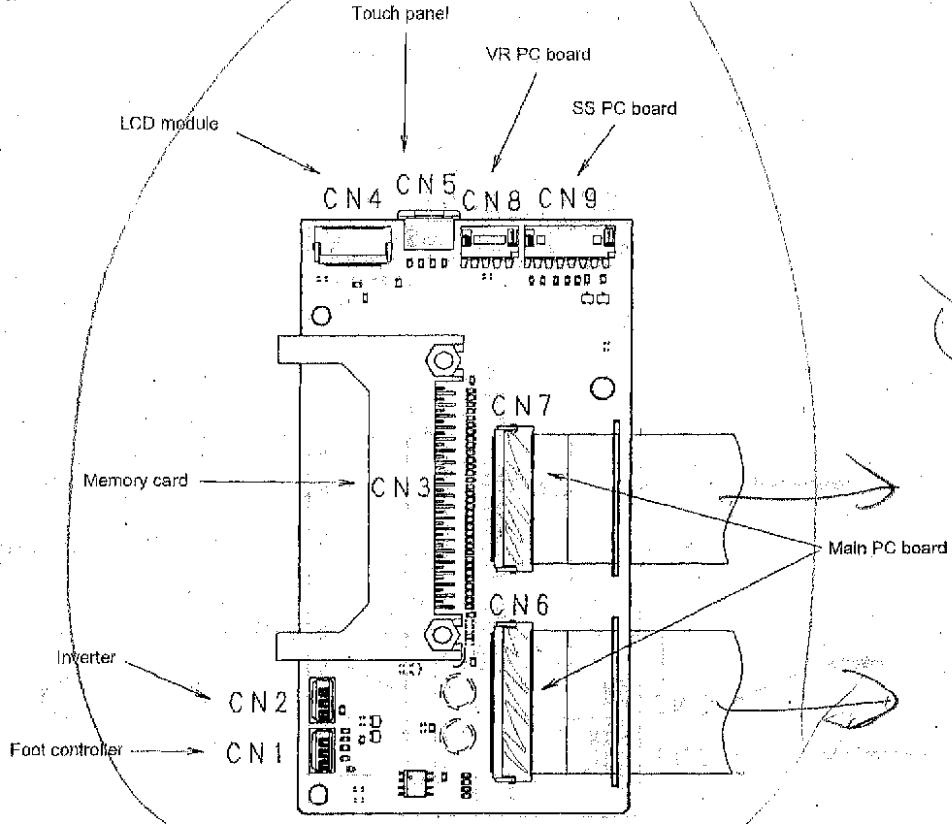

change ok

Other PC boards

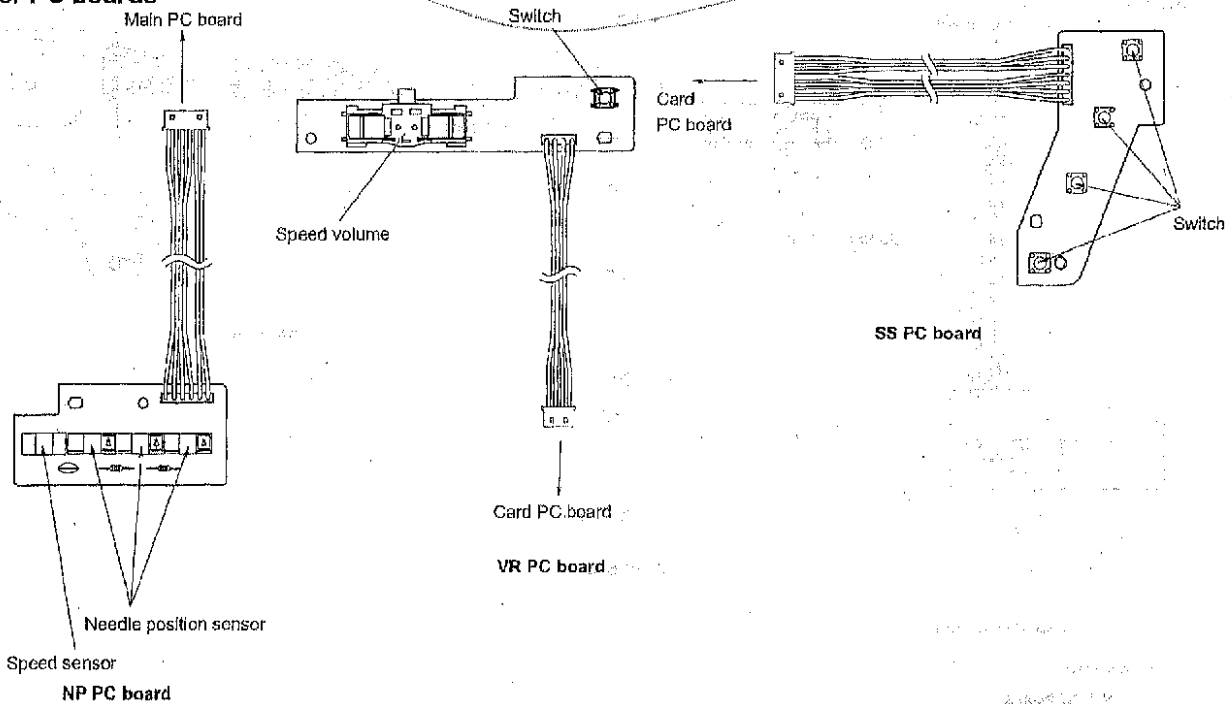

ULT2001
S.G.3000
H0080176
Printed in Japan

**PARTS CATALOGUE FOR
COMPUTERIZED SEWING MACHINE**

**ULT2001
SUPER GALAXIE 3000**

FOR SUBSTITUTION
COMPUTER DRIVEN SYSTEMS

POST 10
SUPER BAKING SERIES

CONTENTS

(1) PRINCIPAL PARTS.....	2
(2) UPPER SHAFT AND NEEDLE BAR	4
(3) FEED MECHANISM	8
(4) ROTARY HOOK, THREAD GUIDE AND THREAD CUTTING	10
(5) LAMP, MAIN PC BOARD ASSEMBLY AND MOTOR UNIT ..	12
(6) EMBROIDERY UNIT	14
(7) OTHER PARTS.....	16
• LCD supply assembly	

(1) PRINCIPAL PARTS

No.	CODE	NAME	REMARKS	No.	CODE	NAME	REMARKS
1	XA1786053	Spool pin		45	XA9411051	Upper cover holder	
2	XA9371051	Shaft		46	XA9641001	Main body lead wire assembly	
3	136681001	Screw B3 x 8		47	XA9773051	Connector holder assembly	
4	087411415	Screw B4 x 14		48	XA9785001	Hardcase assembly	
5	048040346	Stop ring E4		49	XA9861002	Face plate	
6	X57908051	Screw S4 x 10		50	XA9862002	Front cover	
7	X80321001	NT thread cutter assembly		51	XA9863001	SV key top	
8	138384001	CS stop ring CSTW-5		52	XA9864001	SS button for SG3000	
9	XA1800103	Needle threader lever knob			XA9864002	SS button for ULT2001	
10	XA5824151	Needle thread lever		53	XA9865001	Reverse button	
11	XA5825001	Needle thread lever shaft		54	XA9866001	NP button	
12	138260001	Spring		55	XA9867001	Thread cutting button	
13	XC0508000	Washer		56	XA9868001	Bobbin winder button	
14	XA6320000	Shaft presser plate		57	XA9869001	TP-LCD holder	
15	513159001	Washer		58	XA9870002	Upper cover for ULT2001	
16	138433001	Screw B3 x 6			XA9870003	Upper cover for SG3000	
17	052401406	Screw 4 x 14		59	XA9887001	Knee lifter assembly	
18	0A6400806	Screw 4 x 8F		60	XA9947001	Card PCB holder	
19	X57908051	Screw S4 x 10		61	XC0013001	Decoration batch for ULT2001	
20	U12017001	Screw 3 x 6			XC0014001	Decoration batch for SG3000	
21	129074000	Felt		62	060300416	Screw 3 x 4	
22	125440000	Case felt		63	048030346	Stop ring E3	
23	146200001	Stop ring CS4		64	060400616	Screw M4 x 6	
24	138644051	Accessory table notched spring		65	XA6215101	Spring plate	
25	XA9369002	Rear cover		66	XA3028052	Decoration plate	
26	XA9370051	Spool stand bar		67	XA4687051	Adjust screw assembly	
27	XA9372051	Presser plate		68	087412016	Screw 4 x 20	
28	XA9373051	Knoch plate		69	XA9799002	Bobbin winder upper cover	
29	XA9374001	Handle		70	060300616	Screw 3 x 6	
30	XA9375051	Handle holder L assembly		71	XA9872002	Front thread guard cover	
31	XA9379051	Handle holder R assembly		72	060300616	Screw 3 x 6	
32	XA9383001	Free arm cover		73	X81299003	LCD supply assembly for ULT2001	
33	XA9385151	Base plate			X81299004	LCD supply assembly for SG3000	
34	XA9386051	Base plate rubber				including #40,57,61,78,79,80,81 (See the back cover)	
35	XA9387050	Base plate rubber stopper		74	XA9639001	FD unit (FDDFD-05HG-5661)	
36	XA9388001	Base plate cover		75	XA9640001	FD cable (FFCSML2CD-26)	
37	XA9391001	SV joint plate		76	XA9946001	FD holder	
38	XA9397051	Spool pin holder assembly		77	060260316	Screw 26 x 3	
39	XA9400051	Connect cover		78	XA9405001	LCD module (LCDLM8M64)	
40	XA9404001	Touch panel EMU60		79	XA9636001	LCD cable (FFCSML2CD-20)	
41	XA9406001	Accessory table assembly		80	XA6039001	Front cover spacer B	
42	XA9407002	Accessory table front cover		81	085200615	Screw P2 x 6	
43	XA9408001	Accessory table rear cover					
44	XA9409001	Accessory table					

EXPLODED VIEW OF THE CASE

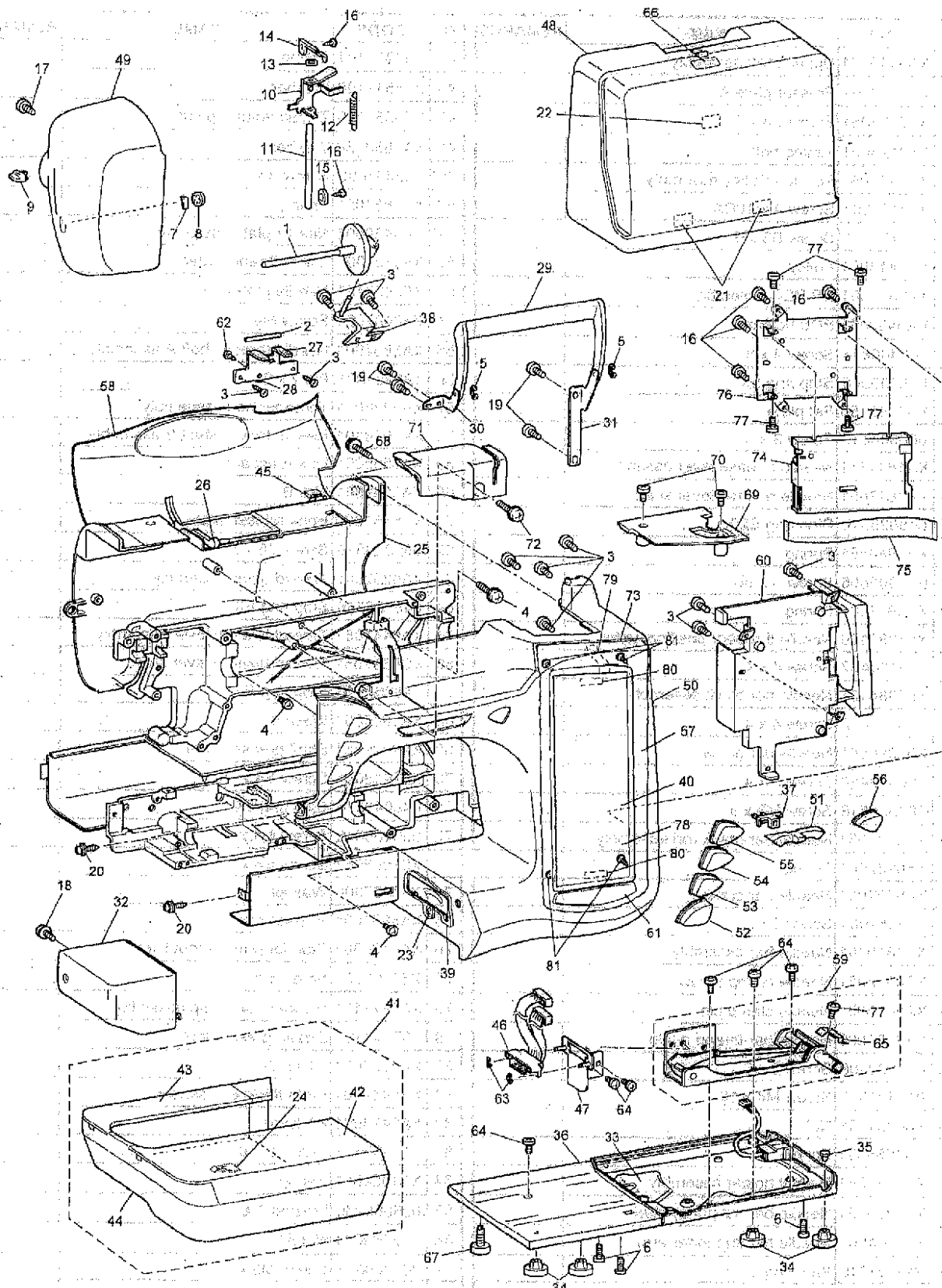

(2) UPPER SHAFT AND NEEDLE BAR

No.	CODE	NAME	REMARKS	No.	CODE	NAME	REMARKS
1	XA9416001	Upper shaft assembly		45	X57822101	Spring	
2	X52478001	Presser plate A		46	X58511100	Washer	
3	X57908051	Screw S4 x 10		47	X50559050	Zigzag adjusting nut	
4	X53125001	Timing belt		48	XA1860150	Washer	
5	XA9425051	Tension Pulley assembly		49	062301006	Screw 3 x 10	
6	138172001	Screw 4 x 10DA		50	XA1861051	Spring	
7	138433001	Screw B3 x 6		51	XA9438001	Needle plate assembly	
8	XA9418001	Pulley		52	X80321001	Lower thread cutter	
9	XA9427001	NP PCB assembly		53	X56828151	Needle plate cover	
10	XA9430051	PCB holder		54	X50487001	Screw M4	
11	060400816	Screw 4 x 8		55	XA5834001	Needle thread shaft A assembly	
12	048030346	Stop ring E3		56	131281001	Pin 2 x 6	
13	XA1843150	Set plate		57	XA5838001	Threader hook assembly	
14	060300616	Screw 3 x 6		58	XA5920101	Needle thread shaft B assembly	
15	XA1844151	Needle release lever assembly		59	XA3565051	Link A assembly	
16	XA1847051	Needle release lever shaft		60	XA3569001	Link B	
17	048025346	Stop ring E2.5		61	XA5851000	Hook release plate	
18	XA1848051	Spring		62	060260516	Screw 26 x 5	
19	0A2300806	Screw 3 x 8B		63	XA5852001	Thread guide assembly	
20	XA5837101	Spring		64	048030346	Stop ring E3	
21	X55983150	Needle threader position setter		65	XA9441051	Thread take-up lever assembly	
22	012400432	Screw 4 x 4		66	XC0397051	Thread take-up lever shaft	
23	X55984101	Needle bar block assembly		67	048050346	Stop ring E5	
24	014400432	Screw 4 x 4		68	XA1866001	Washer	
25	X55990001	Needle bar guide		69	XA9929051	Shaft presser plate	
26	060300416	Screw 3 x 4		70	X57913051	Screw S4 x 16	
27	061300516	Screw M3 x 5		71	048040346	Stop ring E4	
28	XA9431051	Needle bar crank rod assembly		72	060400616	Screw M4 x 6	
29	X58237001	Spring		73	X57908051	Screw S4 x 10	
30	XA9434051	Needle bar crank		74	X53027000	Washer	
31	132051001	Screw 3.57L		75	XA5854001	Presser bar	
32	XA1849101	Needle bar assembly		76	XA6190001	Stud for presser foot lifter	
33	XZ0002051	Needle clamp screw		77	X52760051	Screw 6 x 12	
34	XA6035001	Needle clamp pin		78	XA1870151	Presser bar clamp assembly	
35	XA1851000	Needle bar thread guide		79	137748101	Zigzag presser foot	
36	008020306	Screw 2 x 3		80	XA2222001	PT holder	
37	014401632	Screw M4 x 16		81	XA9447001	Cloth thickness sensor	
38	X56851051	Nut		82	XA6493001	PT lever	
39	XA1856051	Spring		83	012300632	Screw 3 x 6	
40	XA9436051	H shaft holder assembly		84	XA1894051	Spring	
41	XA1859051	Needle bar supporter stud		85	026060235	Washer M6	
42	X56464001	Needle bar supporter arm		86	X52569001	Nut #1	
43	048025346	Stop ring E2.5		87	060300816	Screw M3 x 8	
44	052401406	Screw 4 x 14		88	048050346	Stop ring E5	

6. 8. 10. 12. 14. 16. 18. 20. 22. 24. 26. 28. 30. 32. 34. 36. 38. 40. 42. 44. 46. 48. 50. 52. 54. 56. 58. 60. 62. 64. 66. 68. 70. 72. 74. 76. 78. 80. 82. 84. 86. 88. 90. 92. 94. 96. 98. 100. 102. 104. 106. 108. 110. 112. 114. 116. 118. 120. 122. 124. 126. 128. 130. 132. 134. 136. 138. 140. 142. 144. 146. 148. 150. 152. 154. 156. 158. 160. 162. 164. 166. 168. 170. 172. 174. 176. 178. 180. 182. 184. 186. 188. 190. 192. 194. 196. 198. 200. 202. 204. 206. 208. 210. 212. 214. 216. 218. 220. 222. 224. 226. 228. 230. 232. 234. 236. 238. 240. 242. 244. 246. 248. 250. 252. 254. 256. 258. 260. 262. 264. 266. 268. 270. 272. 274. 276. 278. 280. 282. 284. 286. 288. 290. 292. 294. 296. 298. 300. 302. 304. 306. 308. 310. 312. 314. 316. 318. 320. 322. 324. 326. 328. 330. 332. 334. 336. 338. 340. 342. 344. 346. 348. 350. 352. 354. 356. 358. 360. 362. 364. 366. 368. 370. 372. 374. 376. 378. 380. 382. 384. 386. 388. 390. 392. 394. 396. 398. 400. 402. 404. 406. 408. 410. 412. 414. 416. 418. 420. 422. 424. 426. 428. 430. 432. 434. 436. 438. 440. 442. 444. 446. 448. 450. 452. 454. 456. 458. 460. 462. 464. 466. 468. 470. 472. 474. 476. 478. 480. 482. 484. 486. 488. 490. 492. 494. 496. 498. 500. 502. 504. 506. 508. 510. 512. 514. 516. 518. 520. 522. 524. 526. 528. 530. 532. 534. 536. 538. 540. 542. 544. 546. 548. 550. 552. 554. 556. 558. 560. 562. 564. 566. 568. 570. 572. 574. 576. 578. 580. 582. 584. 586. 588. 590. 592. 594. 596. 598. 600. 602. 604. 606. 608. 610. 612. 614. 616. 618. 620. 622. 624. 626. 628. 630. 632. 634. 636. 638. 640. 642. 644. 646. 648. 650. 652. 654. 656. 658. 660. 662. 664. 666. 668. 670. 672. 674. 676. 678. 680. 682. 684. 686. 688. 690. 692. 694. 696. 698. 700. 702. 704. 706. 708. 710. 712. 714. 716. 718. 720. 722. 724. 726. 728. 730. 732. 734. 736. 738. 740. 742. 744. 746. 748. 750. 752. 754. 756. 758. 760. 762. 764. 766. 768. 770. 772. 774. 776. 778. 780. 782. 784. 786. 788. 790. 792. 794. 796. 798. 800. 802. 804. 806. 808. 810. 812. 814. 816. 818. 820. 822. 824. 826. 828. 830. 832. 834. 836. 838. 840. 842. 844. 846. 848. 850. 852. 854. 856. 858. 860. 862. 864. 866. 868. 870. 872. 874. 876. 878. 880. 882. 884. 886. 888. 890. 892. 894. 896. 898. 900. 902. 904. 906. 908. 910. 912. 914. 916. 918. 920. 922. 924. 926. 928. 930. 932. 934. 936. 938. 940. 942. 944. 946. 948. 950. 952. 954. 956. 958. 960. 962. 964. 966. 968. 970. 972. 974. 976. 978. 980. 982. 984. 986. 988. 990. 992. 994. 996. 998. 1000.

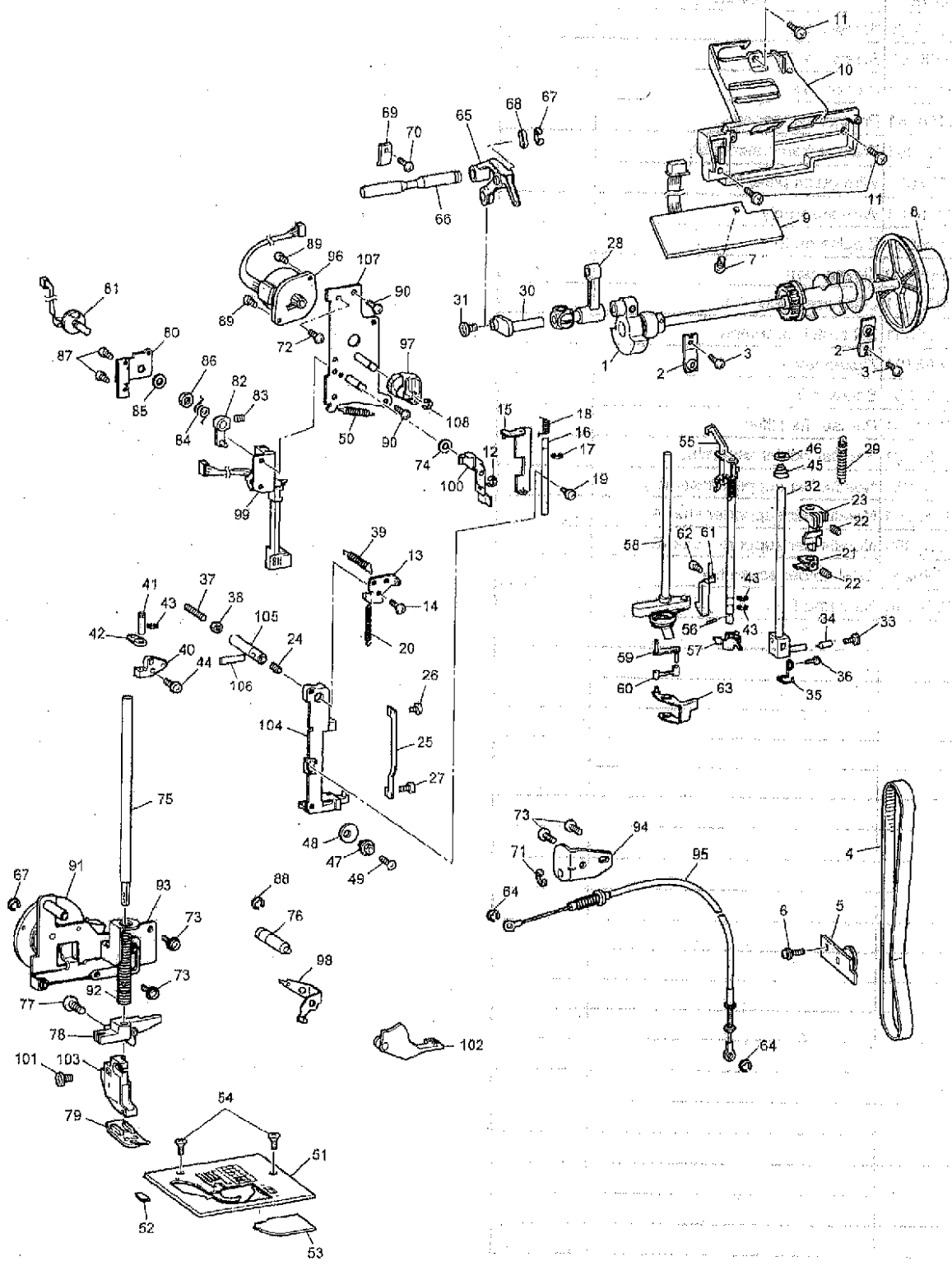

MANUAL FEEDER (3/10)

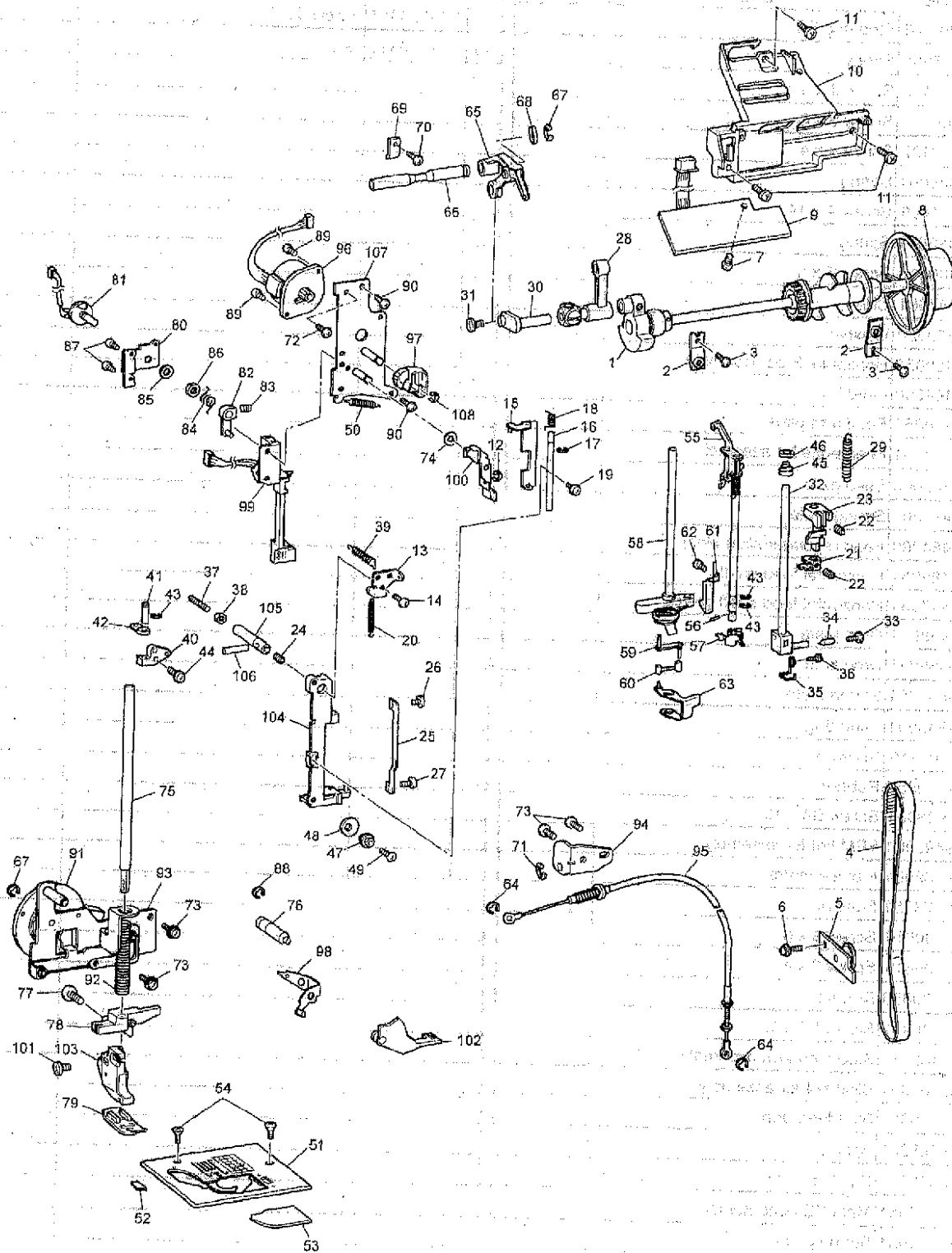

(3) FEED MECHANISM

| No. | CODE | NAME | REMARKS | No. | CODE | NAME | REMARKS |
|-----|-----------|-----------------------------|---------|-----|-----------|--------------|---------|
| 1 | 048050346 | Stop ring E5 | | 45 | 060504016 | Screw 5 x 40 | |
| 2 | X59916051 | Screw | | 46 | 021050315 | Nut 5 | |
| 3 | 012400432 | Screw 4 x 4 | | | | | |
| 4 | 060300616 | Screw 3 x 6 | | | | | |
| 5 | 014400432 | Screw 4 x 4 | | | | | |
| 6 | XA9486001 | Spring | | | | | |
| 7 | 052401406 | Screw 4 x 14 | | | | | |
| 8 | XA9490051 | Spring | | | | | |
| 9 | 060300616 | Screw 3 x 6 | | | | | |
| 10 | 137947001 | Crip | | | | | |
| 11 | X53330000 | Washer | | | | | |
| 12 | XA9463051 | Horizontal feed assembly | | | | | |
| 13 | XA9464050 | Feed bar | | | | | |
| 14 | XA9470051 | Feed arm plate | | | | | |
| 15 | XA9473001 | Feed adjuster assembly | | | | | |
| 16 | XA9482000 | Feed gear | | | | | |
| 17 | XA9483001 | Spring plate | | | | | |
| 18 | XA9484000 | Feed regulator slide block | | | | | |
| 19 | XA9485051 | Horizontal feed shaft | | | | | |
| 20 | XA9487051 | Horizontal feed shaft guide | | | | | |
| 21 | XA9488051 | Drop plate | | | | | |
| 22 | XA9489051 | Drop knob | | | | | |
| 23 | XA9491051 | Spring plate | | | | | |
| 24 | XA9843001 | Feed dog | | | | | |
| 25 | 060300416 | Screw 3 x 4 | | | | | |
| 26 | XA2189050 | Rubber | | | | | |
| 27 | X57908051 | Screw S4 x 10 | | | | | |
| 28 | XA9492001 | FPM holder assembly | | | | | |
| 29 | XA9499001 | F pulse motor | | | | | |
| 30 | XA9923051 | Plate nut | | | | | |
| 31 | 060300616 | Screw 3 x 6 | | | | | |
| 32 | 060300416 | Screw 3 x 4 | | | | | |
| 33 | XA2189050 | Rubber | | | | | |
| 34 | X57908051 | Screw S4 x 10 | | | | | |
| 35 | XA9462051 | Side feed arm assembly | | | | | |
| 36 | XA9501001 | SPM holder assembly | | | | | |
| 37 | XA9506051 | Side feed gear | | | | | |
| 38 | XA9508051 | Spring | | | | | |
| 39 | XA9509001 | S pulse motor | | | | | |
| 40 | XA9510051 | Main PC plate holder D | | | | | |
| 41 | XA9514051 | Spring plate | | | | | |
| 42 | XC0411001 | S stoper | | | | | |
| 43 | XA8390001 | Screw 3 x 7 | | | | | |
| 44 | 060300616 | Screw 3 x 6 | | | | | |

FIG. 10. DETAIL OF THE ROTARY HOOD AND THE BALL CUTTING

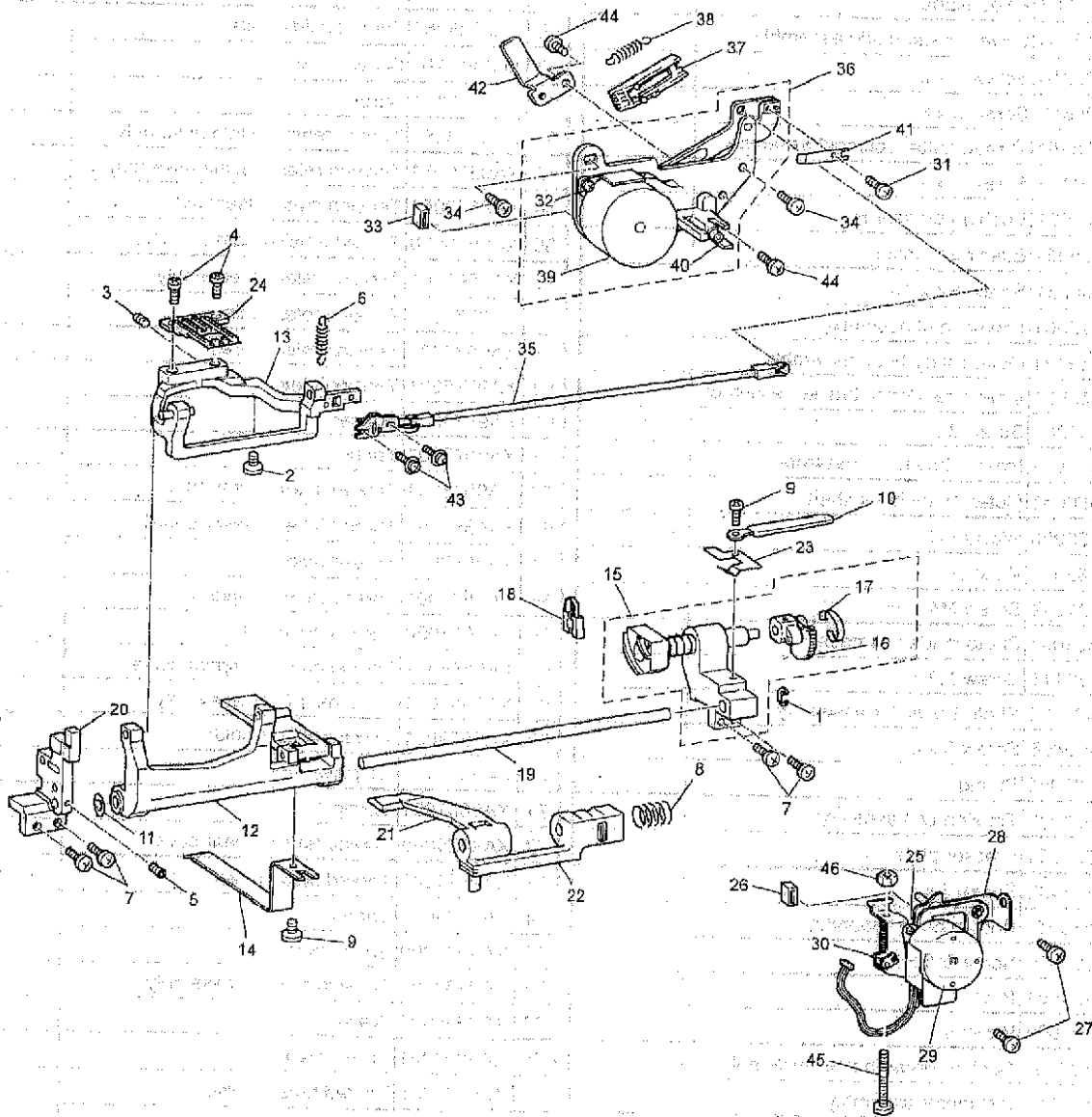

(4) ROTARY HOOK, THREAD GUIDE AND THREAD CUTTING

| No. | CODE | NAME | REMARKS | No. | CODE | NAME | REMARKS |
|-----|-----------|------------------------------------|---------|-----|-----------|--------------------------------|---------|
| 1 | X53169050 | Band | | 45 | XA2189050 | Rubber | |
| 2 | XA9515151 | Thread cutter assembly | | 46 | 060300416 | Screw 3 x 4 | |
| 3 | XA2848151 | Movable blade assembly | | 47 | X57908051 | Screw S4 x 10 | |
| 4 | X56133001 | Fixed blade | | 48 | 052300606 | Screw 3 x 6 | |
| 5 | XA9518051 | Lower thread guide assembly | | 49 | XA2935051 | Thread guide plate | |
| 6 | 060400816 | Screw 4 x 8 | | 50 | 060300616 | Screw 3 x 6 | |
| 7 | 060300616 | Screw 3 x 6 | | 51 | X57605001 | Spring | |
| 8 | XA2578251 | Thread cutter solenoid assembly | | 52 | XA9553051 | Thread tension plate assembly | |
| 9 | 060300416 | Screw 3 x 4 | | 53 | XA9559051 | Tension release plate assembly | |
| 10 | 132421001 | Bushing presser R | | 54 | XA9562051 | Tension plate assembly | |
| 11 | XA1975051 | Bushing presser L | | 55 | XA9565000 | Thread tension cam | |
| 12 | X57908051 | Screw S4 x 10 | | 56 | XA9566001 | Tension release assembly | |
| 13 | XA9522001 | Lower shaft assembly | | 57 | XA9571001 | Tension release link | |
| 14 | XA2855101 | Outer rotary hook assembly | | 58 | XA9573001 | Tension release cam | |
| 15 | XA5869001 | Inner rotary hook bracket assembly | | 59 | XA9575001 | Tension plate | |
| 16 | 0A4301804 | Screw 3 x 18 | | 60 | XA9576001 | Spacer | |
| 17 | XC0426001 | Inner rotary hook assembly | | 61 | XA9577001 | Spring | |
| 18 | XA0360051 | Outer rotary hook shaft | | 62 | XA9578051 | Thread guard assembly | |
| 19 | XA2190000 | Washer U | | 63 | XA9581051 | Thread take-up lever guard | |
| 20 | XA0362001 | Washer | | 64 | XA9582051 | Thread guide | |
| 21 | 014401632 | Screw M4 x 16 | | 65 | XA9583001 | Thread take-up spring | |
| 22 | XA9524001 | Photo diode assembly | | 66 | XA9584050 | Thread guide wire | |
| 23 | 060020416 | Screw M2 x 4 | | 67 | XA9585001 | Thread catching spring case | |
| 24 | XA9526001 | Photo transistor assembly | | 68 | XA9586001 | UT sensor PCB assembly | |
| 25 | 052300606 | Screw 3 x 6 | | 69 | XA9589051 | Thread sensor holder | |
| 26 | XA9787051 | Spring | | 70 | XA9591001 | AT pulse motor | |
| 27 | XA9551001 | Tension unit assembly | | 71 | XA9601051 | Spring | |
| 28 | X50532051 | Presser plate | | 72 | XA9625000 | Thread tension gear cover | |
| 29 | 012300432 | Screw 3 x 4 | | 73 | XA9871002 | Thread guide cover | |
| 30 | XA5876001 | Bobbin base assembly | | 74 | XA9900001 | Spring | |
| 31 | 062260516 | Screw 2.6 x 5 | | 75 | XA9935000 | Spring tape | |
| 32 | 120454001 | Bush | | 76 | XA9938001 | Tension presser assembly | |
| 33 | 137999000 | Washer | | 77 | XA9996001 | Washer | |
| 34 | XA9530051 | Bobbin winder holder assembly | | 78 | XA9997001 | Screw M2 x 3 | |
| 35 | XA9534001 | BW motor assembly | | 79 | 108263001 | Thread tension disc | |
| 36 | XA9540001 | Bobbin pressure | | 80 | 109763003 | Washer | |
| 37 | XA9541051 | Bobbin pressure guide assembly | | 81 | 137881001 | Tension disk washer | |
| 38 | XA9545051 | Spring | | 82 | 137878051 | Thread tension adjusting screw | |
| 39 | XA9546001 | BW switch assembly | | 83 | X58316001 | Thread breakage shutter | |
| 40 | XA9548051 | Spring plate | | 84 | X56323051 | Spring | |
| 41 | XA9549151 | Bobbin winder guide plate | | 85 | XA9449051 | Tension release plate C | |
| 42 | XA9797051 | Thread guide plate | | | | | |
| 43 | 048030346 | Stop ring E3 | | | | | |
| 44 | 048020346 | Stop ring E2 | | | | | |

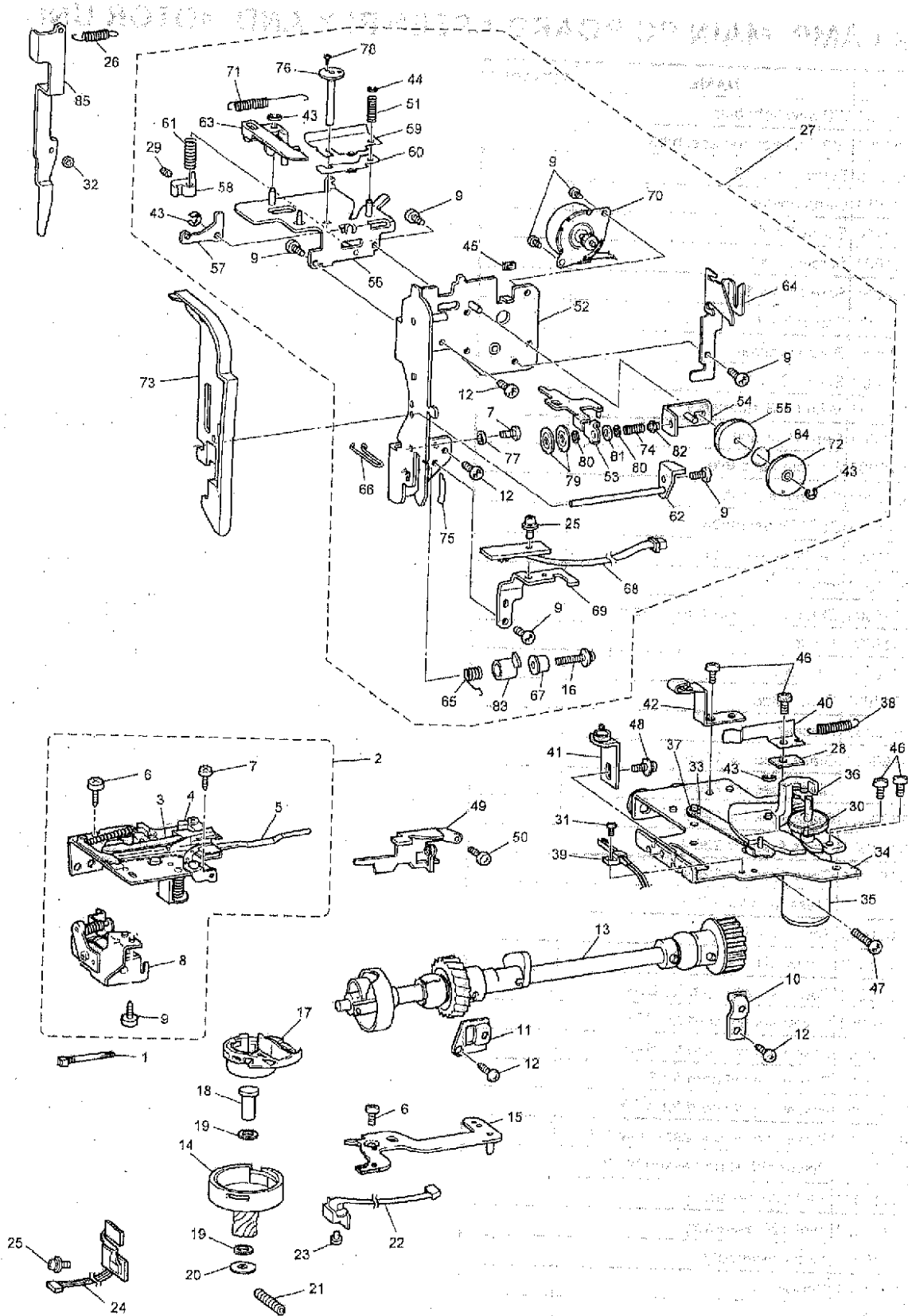

(5) LAMP, MAIN PC BOARD ASSEMBLY AND MOTOR UNIT

| No. | CODE | NAME | REMARKS |
|-----|---|--|---------|
| 1 | XA2037001 | WB sew-light bulb | |
| 2 | XA9596001 | WBL socket sub assembly | |
| 3 | 002261205 | Screw 2.6 x 12 | |
| 4 | XA5879051 | Lamp holder | |
| 5 | 060300416 | Screw 3 x 4 | |
| 6 | 136681001 | Screw B3 x 8 | |
| 7 | X57908051 | Screw S4 x 10 | |
| 8 | 052300606 | Screw 3 x 6 | |
| 9 | XA2220050 | Board presser | |
| 10 | 136681001 | Screw B3 x 8 | |
| 11 | XA9598001 | Main PCB assembly | |
| 12 | XA9619001 | Card PCB unit | |
| 13 | XA9620001 | Flexible flat cable | |
| 14 | XA9621001 | Flexible flat cable | |
| 15 | XA9628001 | SS PCB assembly | |
| 16 | XA9631001 | VR PCB assembly | |
| 17 | XA9634001 | Inverter | |
| 18 | XA9635001 | CFL lead wire sub assembly | |
| 19 | XA9644000 | T belt | |
| 20 | XA9642001 | Set plate R | |
| 21 | XA9643000 | Cord holder | |
| 22 | 026040236 | Washer | |
| 23 | XA9760001 | Glass fuse for 120V
Glass fuse for 230V | |
| 24 | U32809001
XA9761001 | Glass fuse for 120V
Glass fuse for 230V | |
| 25 | XA9762001 | Glass fuse for 120V
Glass fuse for 230V | |
| 26 | 052401406 | Screw 4 x 14 | |
| 27 | 060400616 | Screw M4 x 6 | |
| 28 | XA2815051
XA0070051
X59328051
X57079001
XA1291051 | Power supply cord for CSA
Power supply cord for CEE
Power supply cord for SAA
Power supply cord for BS
Power supply cord for KOREA | |
| 29 | XA9727001
XA9817001 | Power circuit unit assembly 120
Power circuit unit assembly 230 | |
| 30 | XA9941001
XA9961001 | Inlet 230 assembly
Inlet 120 assembly | |
| 31 | XA9645001 | Motor assembly | |
| 32 | XA5901001 | Screw 4 x 14 | |
| 33 | XA9652050 | Fan | |
| 34 | XA7290051
XC0309001 | Foot controller for 120V
Foot controller for 230V | |

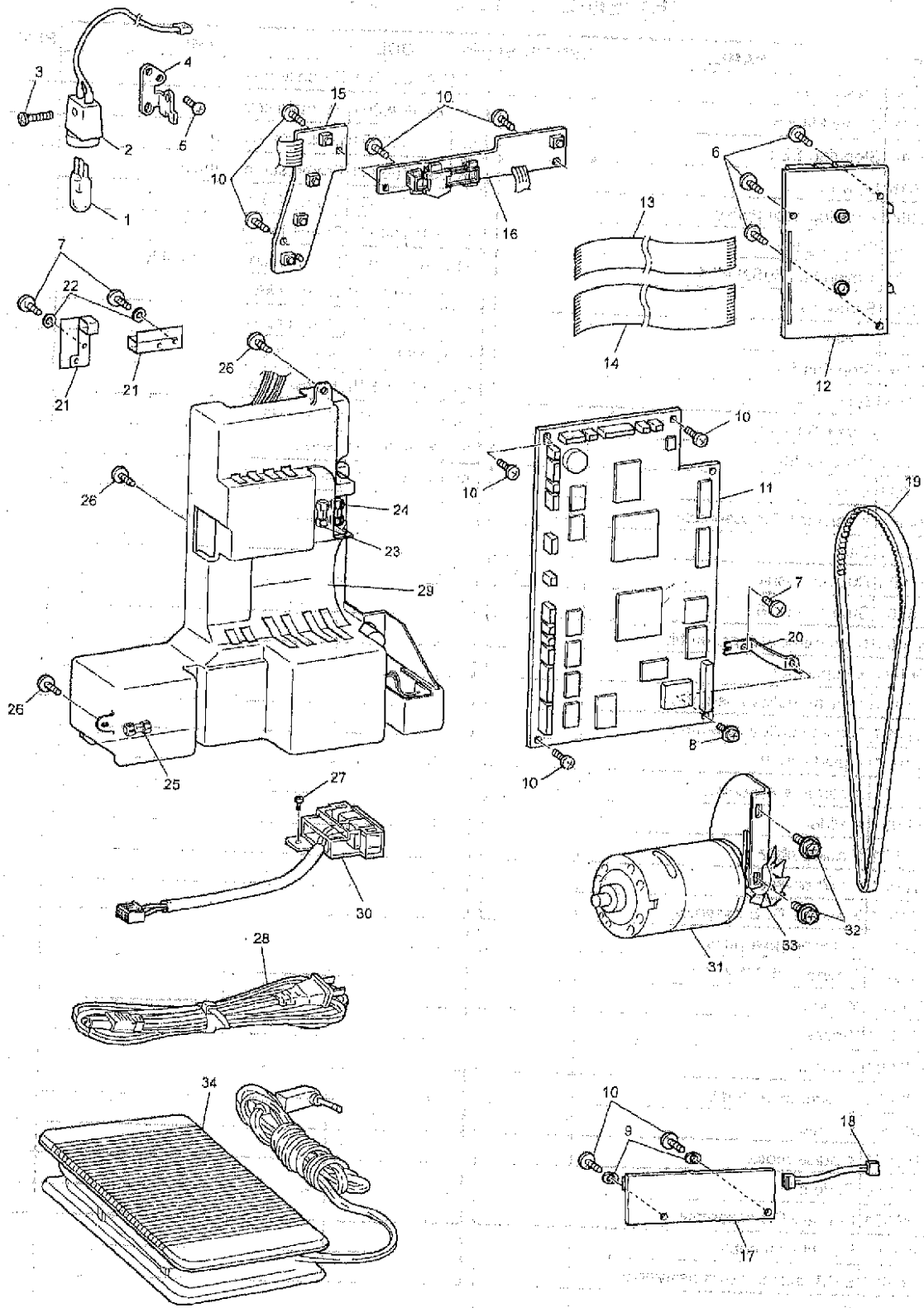

(6) EMBROIDERY UNIT

| No. | CODE | NAME | REMARKS | No. | CODE | NAME | REMARKS |
|-----|-----------|-----------------------------|---------|-----|-----------|------------------------|---------|
| 1 | XA5349050 | Lock finger | | 45 | XA9697001 | ES base cover | |
| 2 | 060400616 | Screw M4 x 6 | | 46 | XA9698001 | ES main cover | |
| 3 | 048025346 | Stop ring E2.5 | | 47 | XA9699001 | Lock release lever | |
| 4 | 060300616 | Screw 3 x 6 | | 48 | XA9700001 | Frame sub assembly | |
| 5 | XA2122050 | X driving gear pulley | | 49 | XA9703001 | Spring 4.6 x 20 | |
| 6 | 048040346 | Stop ring E4 | | 50 | XA9704001 | Frame lock lever | |
| 7 | XA2123001 | Timing belt 60S2M494 | | 51 | XA9793001 | ES main cover assembly | |
| 8 | 052400806 | Screw 4 x 8 | | 52 | XA9795000 | Code guide Y | |
| 9 | 025060235 | Washer | | 53 | XA9832050 | Code crip B | |
| 10 | 048040346 | Stop ring E4 | | 54 | XA8390001 | Screw 3 x 7 | |
| 11 | 052400806 | Screw 4 x 8 | | 55 | 085301615 | Screw P3 x 16 | |
| 12 | 087411415 | Screw B4 x 14 | | 56 | 085301017 | Screw P3 x 10 | |
| 13 | XA0814001 | Pin G4 x 20 | | 57 | XA8390001 | Screw 3 x 7 | |
| 14 | XA2157051 | Spring | | 58 | XC0444001 | Spring 6 x 19 | |
| 15 | XA9684001 | Y sensor PCB assembly | -/01 | | | | |
| 16 | T31049001 | Clip | | | | | |
| 17 | X59853000 | Rubber cushion | | | | | |
| 18 | XA7680001 | Stop ring 9.25 | | | | | |
| 19 | XA9653001 | Main frame sub assembly | | | | | |
| 20 | XA9656001 | X pulse motor | | | | | |
| 21 | XA9657051 | Tension pulley assembly | | | | | |
| 22 | XA9657051 | Tension pulley assembly | | | | | |
| 23 | XA9661001 | X guide shaft | | | | | |
| 24 | XA9662001 | X carriage assembly | | | | | |
| 25 | XA9668001 | X slider | | | | | |
| 26 | XA9669001 | X guide plate | | | | | |
| 27 | XA9670001 | X belt presser | | | | | |
| 28 | XA9671001 | X sensor PCB assembly | | | | | |
| 29 | XA9674001 | Y driving gear pulley | | | | | |
| 30 | XA9675001 | Timing belt 60S2M656 | | | | | |
| 31 | XA9676001 | Y shaft | | | | | |
| 32 | XA9677001 | Washer | | | | | |
| 33 | XA9678001 | Washer | | | | | |
| 34 | XA9679001 | Y carriage assembly | | | | | |
| 35 | XA9682001 | Y slider | | | | | |
| 36 | XA9683001 | Y pulse motor | | | | | |
| 37 | XA9687050 | Code crip | | | | | |
| 38 | XA9688001 | Frame PCB assembly | | | | | |
| 39 | XA9692101 | Flexible flat cable | | | | | |
| 40 | XA9693001 | EMB unit lead wire assembly | | | | | |
| 41 | XA9694001 | Groove cover | | | | | |
| 42 | XA9694001 | Groove cover | | | | | |
| 43 | XA9695002 | X carriage cover | | | | | |
| 44 | XA9696101 | YPM cover | | | | | |

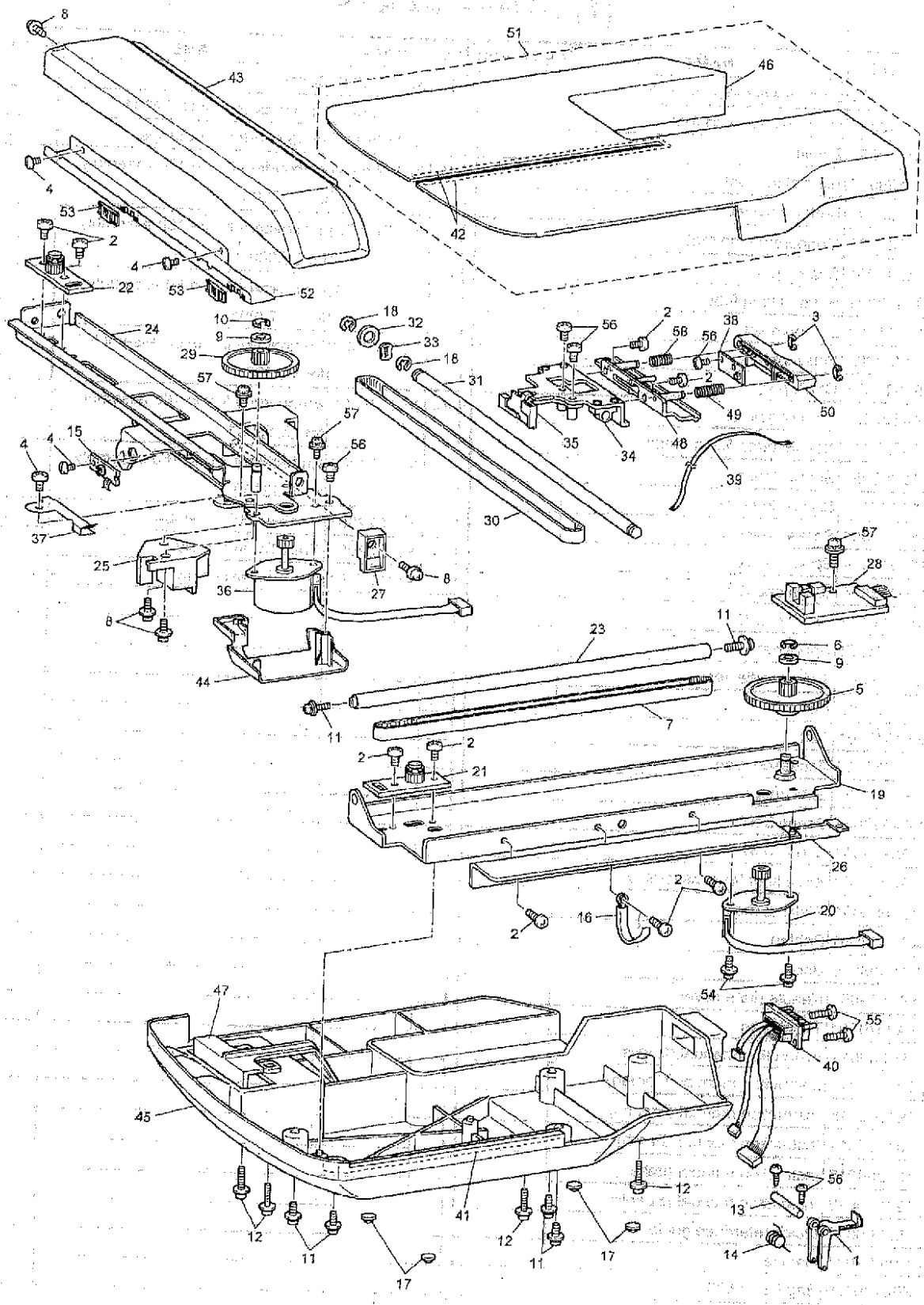

(7) OTHER PARTS

| No. | CODE | NAME | REMARKS | No. | CODE | NAME | REMARKS |
|-----|-----------|------------------------------|---------|-----|-----------|---|---------|
| 1 | XA5500001 | Embroidery foot assembly | | 40 | X61500000 | Carton | |
| 2 | X51162001 | Overcasting stitch-foot | | 41 | X61555001 | Master carton for ULT2001 | |
| 3 | X59370051 | Zipper foot | | | X61556001 | Master carton for Europe | |
| 4 | X56409001 | Blind stitch foot | | 42 | X81273001 | Embroidery frame 100 assembly for ULT2001 | |
| 5 | X57789101 | Button hole foot | | | X81273002 | Embroidery frame 100 assembly for SG3000 | |
| 6 | X53840301 | Monogramming foot | | 43 | X81275001 | Embroidery frame 60 assembly for ULT2001 | |
| 7 | X54243001 | Seam ripper | | | X81275002 | Embroidery frame 60 assembly for SG3000 | |
| 8 | 130489001 | Button fitting foot | | 44 | X81274001 | Embroidery frame 160 assembly for ULT2001 | |
| 9 | X58358001 | Z needle set | | | X81274002 | Embroidery frame 160 assembly for SG3000 | |
| 10 | 184783001 | Scissors | | 45 | X61522001 | Machine SF assembly | |
| 11 | 184944001 | Chalk pen | | 46 | X61507001 | Case SF assembly | |
| 12 | XA4527001 | Cleaning brush | | 47 | X61523001 | Head SF assembly | |
| 13 | 135793001 | Needle plate fixing metal | | | | | |
| 14 | XA2005051 | Screw driver | | | | | |
| 15 | X55467051 | Screw driver M | | | | | |
| 16 | X55468051 | Screw driver S | | | | | |
| 17 | 130012004 | Spool cap A | | | | | |
| 18 | 130013004 | Spool cap B | | | | | |
| 19 | X55260153 | Spool cap C | | | | | |
| 20 | XA3336051 | Spool bar | | | | | |
| 21 | X59296001 | Twin needle set | | | | | |
| 22 | 127610000 | Net | | | | | |
| 23 | X57045001 | Felt | | | | | |
| 24 | XA1363051 | Accessory bag | | | | | |
| 25 | X80943001 | Side cutter | | | | | |
| 26 | XA4813051 | Screw 3.57 | | | | | |
| 27 | XA5904051 | Screw 3.57 | | | | | |
| 28 | XA6941001 | Knee lifter lever assembly | | | | | |
| 29 | X81065001 | Walking foot | | | | | |
| 30 | XA3812051 | Bobbin | | | | | |
| 31 | XA0188000 | Bag | | | | | |
| 32 | XA9939051 | Needle plate cover | | | | | |
| 33 | XA9940001 | Touch pen | | | | | |
| 34 | 191200011 | Instruction manual (English) | | | | | |
| | 191200013 | Instruction manual (German) | | | | | |
| | 191200015 | Instruction manual (French) | | | | | |
| | 191200014 | Instruction manual (Dutch) | | | | | |
| | 191200016 | Instruction manual (Italian) | | | | | |
| | 191200012 | Instruction manual (Spanish) | | | | | |
| 35 | 192200011 | Quick reference guide | | | | | |
| 36 | 418859001 | Handle | | | | | |
| 37 | X60439100 | Bag 630 x 630 | | | | | |
| 38 | X61569001 | Pad D200 | | | | | |
| 39 | X61505001 | Embroidery carton D | | | | | |

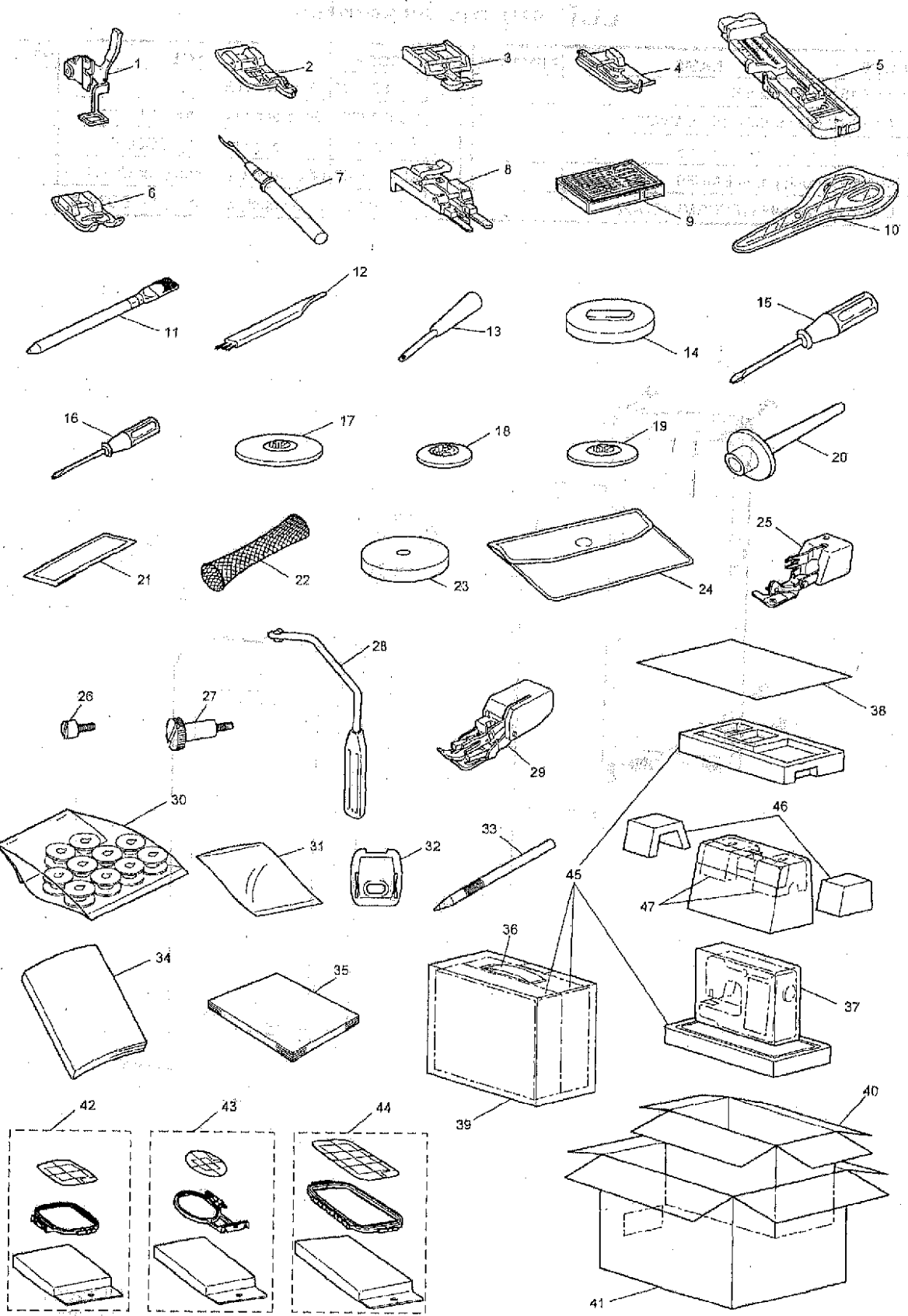

• LCD supply assembly

| No. | CODE | NAME | REMARKS | No. | CODE | NAME | REMARKS |
|-----|-----------|--------------------------|---------|-----|-----------|---------------------------------|---------|
| 1 | 085200615 | Screw P2 x 6 | | 6 | XA9869001 | TP-LCD holder | |
| 2 | XA9405001 | LCD module (LCDLM8M64) | | 7 | XC0013001 | Decoration batch for ULT2001 | |
| 3 | XA6039001 | Front cover spacer B | | | XC0014001 | Decoration batch for SG3000 | |
| 4 | XA9404001 | Touch panel EMU60 | | 8 | X81299003 | LCD supply assembly for ULT2001 | |
| 5 | XA9636001 | LCD cable (FFCSML2CD-20) | | | X81299004 | LCD supply assembly for SG3000 | |

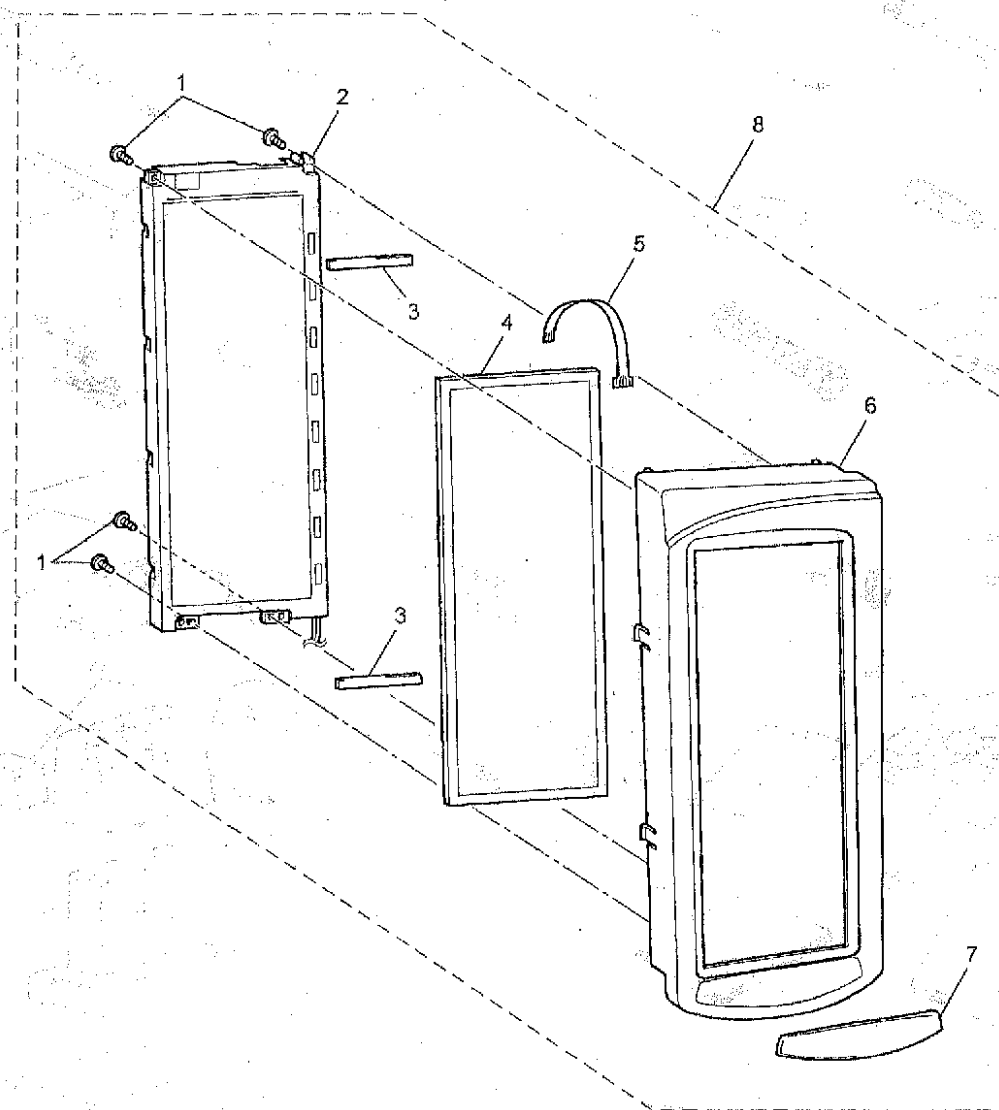

ULT2001
S.G.3000
H0080177